

COXREELS® DEF Series are equipped with a stainless steel external full-flow swivel and chemical resistant Viton® seals to provide a safe, reliable Diesel Exhaust Fluid (DEF) dispensing solution. The swivel is easy to access for simple seal maintenance and fast DEF dispenser hose installation. Coxreels® professional DEF reeling systems are available in heavy-duty single pedestal (SH Series) or supreme-duty dual pedestal (T Series) configurations. Both versatile designs are outfitted with Coxreels' original Super Hub™ dual axle support systems to increase stability and reduce vibration during operation, making these reels the perfect DEF handling solutions for either stationary or rugged mobile applications.

DEF SERIES

Models are equipped with DEF hose. Note: Do not exceed listed hose O.D. to obtain maximum length.

HOSE							LESS HOSE		SIZE INDEX
MODEL	I.D.	O.D.	FT.	PSI	APPR. LBS.	EZ-COIL MODELS	MODEL	APPR. LBS.	
DEF-SH SERIES									
-	1/2"	7/8"	50	300	-	-	*SHL-N-450-BBX	46	1
SH-N-525-DF-BBX	3/4"	1 1/16"	25	300	52	EZ-SH-525-DF-BBX	SHL-N-525-DF-BBX	45	2
SH-N-550-DF-BBX	3/4"	1 1/16"	50	300	69	EZ-SH-550-DF-BBX	SHL-N-550-DF-BBX	56	3
DEF-T SERIES									
-	1/2"	3/4"	50	300	-	-	*TSHL-N-450-BBX	55	4
-	3/4"	1 1/16"	35	300	-	-	*TSHL-N-535-DF-BBX	67	5
TSH-N-550-DF-BBX	3/4"	1 1/16"	50	300	83	EZ-TSH-550-DF-BBX	TSHL-N-550-DF-BBX	70	5
-	1"	1 1/2"	35	300	-	-	TSHL-N-635-BBX	71	6
-	1"	1 1/2"	50	300	-	-	TSHL-N-650-BBX	77	7
DEF-XTM SERIES									
XTM-LP-550-DF-BBX	1"	1 1/2"	50	300	94	-	-	-	8

*EZ-Coil® option only available on these less hose models. Please add prefix "EZ-"



DEF SERIES :: REEL SPECIFICATIONS

SWIVEL

- Non-corrosive stainless steel 90° full flow NPT swivel for Diesel Exhaust Fluid (DEF) dispensing applications.
- Swivel seals: Viton®

HOSE

- DEF dispensing hose designed to convey the high-purity, aqueous urea solution DEF.
- Temperature Range: -40°F to +257°F

DESIGN & STRUCTURE

- **On SH Models only** - Sturdy single pedestal reel features Coxreels' exclusive Super Hub™ dual axle support system
- **On T Models only** - Sturdy dual pedestal reel features Coxreels' exclusive Super Hub™ triple axle support system. Stainless Steel rollers on 3/4" & 1" models
- **On XTM Models only** Fully welded box frame construction, welded seams & redundant flanges. Wider frames feature Coxreels' exclusive Super Hub™ triple axle support system. Stainless Steel rollers
- **On SH & T Models only** - Guide arm adjusts to wall, floor, vehicle & overhead positions. Solid one piece, heavy gauge 1/4" steel base & support posts for maximum strength. 1" solid steel axle & lubricated precision bearings for smooth rotation
- Non-sparkling mechanism

RETRACTION

- See each series page

SIGNATURE FEATURES

- Professional grade heavy duty steel construction
- Durable proprietary CPC™ powder coat process
- Rolled edges & ribbed discs provide strength & safety
- Leading 2-year manufacturer's limited warranty
- Made in the U.S.A. - Sold & Supported Worldwide

POSSIBLE FIELDS OF APPLICATION

- Vehicle Refueling
- Tank Trucks
- Fuel/Lube Trucks
- Fuel Storage & Dispensing Systems
- DEF Storage & Dispensing Systems
- Aircraft Refueling
- Marine/Ship Refueling/ Offshore

ACCESSORIZE YOUR REEL :: PG 56

- O-Rings & Swivels
- Mounting Brackets
- Hoses
- Assorted Reel Accessories

REEL DIMENSIONS

Technical Data Sheets Available On Website

SIZE INDEX	W	H	L	X	Y	M	N
1	8 1/4"	21 1/4"	19 1/2"	6"	6"	4"	5"
2	9 3/8"	21 1/4"	19 1/2"	6"	6"	4"	5"
3	9 7/8"	25 1/2"	24"	6"	6"	4"	5"
4	9 3/8"	21 1/4"	19 1/2"	8"	9"	7"	8"
5	9 7/8"	25 1/2"	24"	8"	9"	7"	8"
6	10"	25 1/2"	24"	8"	9"	7"	8"
7	12"	25 1/2"	24"	8"	9"	7"	8"
8	10 1/8"	26 1/8"	24 1/16"	10"	15"	8 29/32"	10"

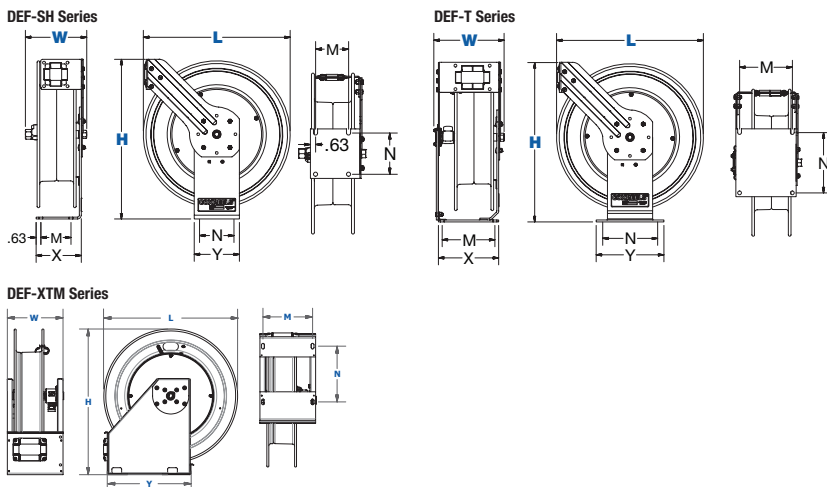

WARNING: Cancer and reproductive Harm – See page 63 for more information – www.P65Warning.ca.gov



SPRING DRIVEN

EZ-COIL®