

Expandable Metal Cabinets

AVAILABLE IN: **SPRING DRIVEN**

EZ-COIL®

E SERIES

COXREELS® E Series "Expandable" multiple bank system is the pinnacle in professional appearance and organization. The cabinets are interlocking and expandable to any number of spring driven reel assemblies required. Designed for easy installation, maintenance and servicing the E Series system is truly the professional's choice for multimedia delivery in one custom package.

LOW PRESSURE Models with hose are for air or water service with a maximum temperature 150° F. Models less hose can be used for air, water or oil. **NOTE: Do not exceed listed hose O.D. to obtain maximum length.**

| HOSE | | | | | | LESS HOSE | | SIZE INDEX |
|-----------------|------|--------|-----|-----|------------|------------------|------------|------------|
| MODEL | I.D. | O.D. | FT. | PSI | APRX. LBS. | MODEL | APRX. LBS. | |
| E-LP-330 | 3/8" | 21/32" | 30 | 300 | 33 | E-LPL-330 | 29 | 1 |
| E-LP-350 | 3/8" | 21/32" | 50 | 300 | 46 | E-LPL-350 | 40 | 2 |
| E-LP-430 | 1/2" | 27/32" | 30 | 300 | 41 | E-LPL-430 | 36 | 1 |
| E-LP-450 | 1/2" | 27/32" | 50 | 300 | 50 | E-LPL-450 | 42 | 2 |

MEDIUM PRESSURE Reels are furnished with standard one wire braid hose suitable for air, water or oil applications. Hose exceeds SAE R1 specifications. Maximum temperature 250° F. **NOTE: Do not exceed listed hose O.D. to obtain maximum length.**

| HOSE | | | | | | LESS HOSE | | SIZE INDEX |
|-----------------|------|------|-----|------|------------|------------------|------------|------------|
| MODEL | I.D. | O.D. | FT. | PSI | APRX. LBS. | MODEL | APRX. LBS. | |
| E-MP-330 | 3/8" | 5/8" | 30 | 3000 | 47 | E-MPL-330 | 39 | 1 |
| E-MP-350 | 3/8" | 5/8" | 50 | 3000 | 61 | E-MPL-350 | 49 | 2 |
| E-MP-430 | 1/2" | 3/4" | 30 | 2500 | 47 | E-MPL-430 | 39 | 1 |
| E-MP-450 | 1/2" | 3/4" | 50 | 2500 | 63 | E-MPL-450 | 49 | 2 |

HIGH PRESSURE Reels are furnished standard with S.A.E. 100R16 #1 or #2 wire braid hose suitable for grease and hydraulic oil applications. Maximum temp. 250° F. **NOTE: Do not exceed listed hose O.D. to obtain maximum length.**

| HOSE | | | | | | LESS HOSE | | SIZE INDEX |
|-----------------|------|--------|-----|------|------------|------------------|------------|------------|
| MODEL | I.D. | O.D. | FT. | PSI | APRX. LBS. | MODEL | APRX. LBS. | |
| E-HP-130 | 1/4" | 17/32" | 30 | 5000 | 46 | E-HPL-130 | 39 | 3 |
| E-HP-150 | 1/4" | 17/32" | 50 | 5000 | 60 | E-HPL-150 | 49 | 4 |
| E-HP-330 | 3/8" | 43/64" | 30 | 4000 | 47 | E-HPL-330 | 39 | 3 |
| E-HP-350 | 3/8" | 43/64" | 50 | 4000 | 61 | E-HPL-350 | 49 | 4 |

REEL DIMENSIONS

Technical Data Sheets Available On Website

| SIZE INDEX | A | B | C | D | E | MOUNT L-M |
|------------|--------|---------|---------|----|----|-----------|
| 1 | 6 1/8" | 18 1/4" | 17 1/4" | 6" | 6" | 4" - 5" |
| 2 | 8 3/4" | 21" | 19 5/8" | 6" | 6" | 4" - 5" |
| 3 | 7" | 18 1/4" | 17 1/4" | 6" | 6" | 4" - 5" |
| 4 | 9 1/4" | 21" | 19 5/8" | 6" | 6" | 4" - 5" |

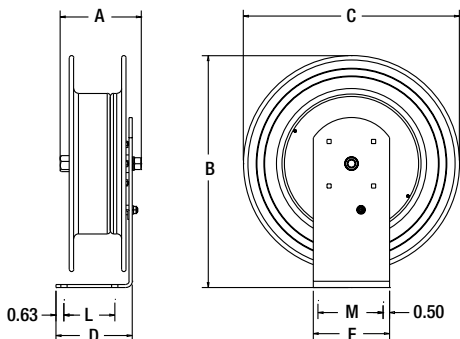

Cabinet illustration (above) shows three reels, three metal cabinets, & one set of end panels

BUILD YOUR ARSENAL!

E SERIES Offers...

Hose I.D.: 1/4" - 1/2" **Pressure:** To 5,000 PSI

- ✓ Attractive Multiple Reel Bank System
- ✓ Swivel Seals: NITRILE

SPRING DRIVEN FEATURES:

- ✓ Auto Rewind Easily Wraps, Stores & Protects Hose
- ✓ Heavy Gauge Steel Base & Support Post
- ✓ Factory-Matched & Lubricated Cartridge-Style Spring Motor
- ✓ Brass NPT Swivel Inlet Machined From Solid (Zinc Plated Steel On HP Models)
- ✓ 1" Solid Steel Axle With 1" Lubricated Precision Bearings
- ✓ Multi-Position Lock Ratchet Secures Hose At Desired Length
- ✓ Non-Corrosive Stainless Steel Spring, Pawl & Zinc Plated Ratchet

CABINET Offers...

Length: 24 1/2" **Width:** 11 1/8" **Height:** 22 1/4"

- ✓ Unlimited Expandability
- ✓ Easy To Install
- ✓ Cabinet Constructed Of 14 Gauge Steel With 4-Roller Non-Snag Hose Guide System For Reduced Hose Wear
- ✓ All Steel Access Panel
- ✓ Mounting Bracket Is 3/16" Bent Steel, Fits 3" To 8 1/2" Flange On "I" Or "H" Beam
- ✓ Easy Access For Connection Of Air, Water, Oil & Grease

METAL CABINET: #1796-2 - Includes cabinet, access panel & mounting bracket. Weight: 45 lbs.
END PANELS: #1798-1 - Includes a set of two, all steel construction. Finished & caps the ends of each bank. Weight: 8 lbs.



End Panels Sold Separately

COXREELS® SIGNATURE FEATURES:

- ✓ Professional Grade Heavy Duty Steel Construction
- ✓ Durable Proprietary CPC™ Powder Coat Process
- ✓ Rolled Edges & Ribbed Discs Provide Strength & Safety
- ✓ Leading 2-Year Manufacturer's Limited Warranty
- ✓ Made In The U.S.A. Sold & Supported Worldwide

AVAILABLE OPTIONS

UPGRADE TO EZ-COIL®

INCREASE OPERATOR SAFETY
AVOID PERSONAL INJURY
LONGER REEL LIFE



See Page 3 For More Details

HOSE UPGRADE

PROTECTION FROM THE ELEMENTS
EXTENDED HOSE LIFE
APPLICATION SPECIFIC



See Page 33 For More Details

STAINLESS STEEL

SWIVELS & PLUMBING
FOR PURE PRODUCT FLOW
APPLICATIONS



Consult Factory For Details

HOW TO ORDER?

See Page 5 For Details

NEED SPECIAL O-RINGS

See Page 35 For Details



Toll Free 800-COX-REEL • Fax 800-229-REEL • Int 480-820-6396 • Fax 480-820-5132 • www.coxreels.com

