

Large Capacity Welding Reels

1275W-C & 100W SERIES

AVAILABLE IN: **HAND CRANK**
MOTOR DRIVEN

COXREELS® 1275W Series hand crank or motorized "Welding" hose reels are built to manage long lengths of bulky twin line welding hose. The direct bevel gear drive, low profile outlet riser and open drum slot design are features greatly appreciated by the regular user. Dual brass swivel inlets on each side of the reel assure full flow trouble free performance.

COXREELS® 100W Series "Welding" hand crank hose reels are lightweight, compact and versatile. Save time and effort while increasing the safety of your work environment. The sturdy "U" shaped frame and all steel construction make this one tough little reel. All listed models are supplied less hose.

1275W-C SERIES

HOSE						LESS HOSE		SIZE INDEX
MODEL	I.D.	O.D.	FT.	PSI	APRX. LBS.	MODEL	APRX. LBS.	
1275W-3-100-C	3/8"	2 3/8"	100	200	73	1275WL-3-100-C	45	1
1275W-3-150-C	3/8"	2 3/8"	150	200	90	1275WL-3-150-C	48	2
1275W-3-250-C	3/8"	2 3/8"	250	200	126	1275WL-3-250-C	56	3
-	-	-	-	-	-	1275WL-3-350-C	64	4

100W SERIES

HOSE						LESS HOSE		SIZE INDEX
MODEL	I.D.	O.D.	FT.	PSI	APRX. LBS.	MODEL	APRX. LBS.	
112W-1-50	1/4" Twin	17/32" Twin	50	200	28	112WL-1-50	18	-
112W-1-100	1/4" Twin	17/32" Twin	100	200	37	112WL-1-100	18	5

1275W-C MOTOR DRIVEN MODELS

When ordering, suffix the model number with selection below. *Add on approximate lbs to ship weight.

SUFFIX	TYPE	DESCRIPTION	ADD ON APRX. LBS.*
A	AIR - #4 GAST	COMP. AIR MOTOR	8
H	HYDRAULIC	END PORTED 9/16-18 UNF REV.	6
C	CRANK	BEVEL GEAR	3

*Add 5 lbs to ship weight if reel is crated

REEL DIMENSIONS

Technical Data Sheets Available On Website

SIZE INDEX	A	B	C	D	E	F	G	L	M
1	6 1/4"	8"	17 1/2"	13 3/8"	19 5/16"	15 1/8"	18 1/8"	-	-
2	6 1/4"	12"	17 1/2"	17 3/8"	23 5/16"	15 1/8"	18 1/8"	-	-
3	6 1/4"	18"	17 1/2"	23 3/8"	29 5/16"	15 1/8"	18 1/8"	-	-
4	6 1/4"	24"	17 1/2"	29 3/8"	35 5/16"	15 1/8"	18 1/8"	-	-
5	5 1/2"	8"	12"	9 1/2"	18 3/4"	-	13"	3"	5 1/2"

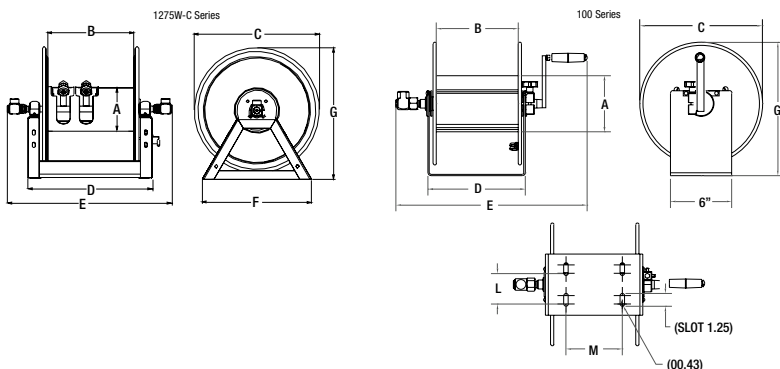

**WELDED FRAMES?
BOLTED FRAMES?
WE KNOW**

Sturdy All Welded "A" Frame Base

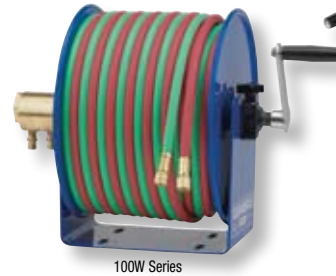

1275W-C Series, Shown With Optional Rollers

100W Series

1275W-C SERIES Offers...

- Hose I.D.: 3/8" Twin Pressure: To 200 PSI
- ✓ Designed For Oxy-Acetylene & "T" Grade Welding Hose
- ✓ Applications Include MAPP Gas, Propane, & Natural Gas
- ✓ Both 3/8" Solid Machined Brass Swivel Inlets With Welding Fittings
- ✓ Bevel Gear Hand Crank With Removable Handle For Compact Storage Or Bevel Gear Motor Driven Retraction (See Motor Driven Chart)
- ✓ Low Profile Outlet Riser & Open Drum Slot Design
- ✓ Brake Assembly Provides Adjustable Friction To Brake Or Lock The Drum
- ✓ Self-Aligning Pillow Block Bearings Ensure Smooth Rotation
- ✓ Long-Handled Lock Pin Secures Reel When Not In Use

100W SERIES Offers...

- Hose I.D.: 1/4" Twin Pressure: To 200 PSI
- ✓ Light Weight Compact Design
- ✓ Direct Hand Crank Action
- ✓ Dual Ported Brass Swivel Is Machined From Solid & Offers Both Connections From The Same Side Of Reel
- ✓ Brake Assembly Provides Adjustable Friction To Brake Or Lock The Drum
- ✓ Composite Bearings For Smooth Rotation
- ✓ Designed For 100 Feet Of 1/4" Twin Line R-Grade Oxy-Acetylene Welding Hose
- ✓ 9/16" - 18 UNF Welding Hose Fittings

COXREELS® SIGNATURE FEATURES:

- ✓ Professional Grade Heavy Duty Steel Construction
- ✓ Durable Proprietary CPC™ Powder Coat Process
- ✓ Rolled Edges & Ribbed Discs Provide Strength & Safety
- ✓ Leading 2-Year Manufacturer's Limited Warranty
- ✓ Made In The U.S.A. Sold & Supported Worldwide

HOW TO ORDER?

See Page 5 For Details

AVAILABLE OPTIONS

ROLLER BRACKETS



IMPROVE HOSE HANDLING FROM ANY DIRECTION
MANY STYLES AVAILABLE
See Page 34 For Selection

SWITCHES & SPEED CONTROLLERS



ADJUST & SET REWIND SPEED
CONVENIENT ON/OFF CONTROL
REVERSE/FORWARD CAP.
MANY STYLES AVAILABLE
See Page 34 For Details



Toll Free 800-COX-REEL • Fax 800-229-REEL • Int 480-820-6396 • Fax 480-820-5132 • www.coxreels.com

