

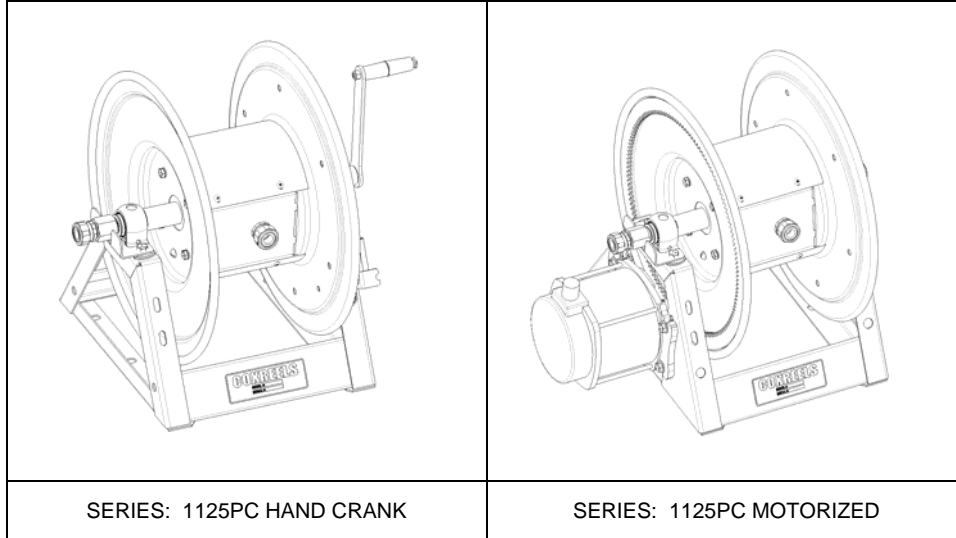

HAND CRANK & MOTORIZED POWER CORD REELS:
SERIES 1125PC



SERIES: 1125PC HAND CRANK

SERIES: 1125PC MOTORIZED

COXREELS

The technical data and images which appear in this manual are for informational purposes only. NO WARRANTIES, EXPRESS OR IMPLIED, INCLUDING WARRANTIES OF MERCHANTABILITY OR FITNESS FOR A PARTICULAR PURPOSE, ARE CREATED BY THE DESCRIPTIONS AND DEPICTIONS OF THE PRODUCTS SHOWN IN THIS MANUAL.

COXREELS agrees to repair or exchange the goods sold hereunder necessitated by reason of defective workmanship and material discovered and reported to COXREELS within two years after original invoice date.

Except where the nature of the defect is such that it is appropriate, in COXREELS' judgment, to effect repairs on site, COXREELS' obligation hereunder to remedy defects shall be limited to repairing or replacing (at COXREELS' option) FOB COXREELS Factory, any part returned to COXREELS at the risk and cost of Buyer.

COXREELS shall only be obligated to make such repair or replacement if the goods have been used by Buyer only in service recommended. COXREELS is not responsible for defects which arise from improper installation, neglect, improper use of or from normal wear and tear.

COXREELS obligation shall be limited by the manufacturer's warranty (and is not further warranted by COXREELS) for all parts procured from others according to published data, specifications or performance information not designed by COXREELS.

COXREELS further agrees to replace or at COXREELS' option to provide a refund of the sales price of any goods that do not conform to applicable specifications or which differ from that agreed to be supplied which non-conformity is discovered and forthwith reported to COXREELS within 30 days after shipment to the Buyer.

COXREELS liability on any claim, whether in contract, tort (including negligence), or otherwise, for any loss or damage arising out of, connected with, or resulting from the manufacture, sale, delivery, resale, repair, replacement or use of any products or services shall in no case exceed the price paid for the product or services or any part thereof which give rise to the claim.

COXREELS is not responsible for incorrect choice of models or where products are used in excess of their rated and recommended capacities and design functions or under abnormal conditions. COXREELS assumes no liability for loss of time, damage or injuries to property or persons resulting from the use of COXREELS products.

NOTE: All designs, specifications, and dimensional data contained in this publication are subject to change without notice.



## WARNING – APPLICATION

- ❖ THE PRODUCTS IN THIS INSTALLATION AND MAINTENANCE MANUAL HAVE BEEN TESTED UNDER CONTROLLED LABORATORY CONDITIONS TO MEET SPECIFIC TEST CRITERIA. THESE TESTS ARE NOT INTENDED TO REFLECT THE PERFORMANCE OF THE PRODUCTS OR ANY OTHER MATERIAL IN ANY SPECIFIC APPLICATION, BUT ARE INTENDED TO PROVIDE THE USER WITH APPLICATION GUIDELINES. THE PRODUCTS ARE INTENDED FOR USE BY KNOWLEDGEABLE PERSONS HAVING THE TECHNICAL SKILL NECESSARY TO EVALUATE THEIR SUITABILITY FOR SPECIFIC APPLICATIONS.



## WARNING – USER RESPONSIBILITY

- ❖ THE USER, THROUGH ITS OWN ANALYSIS AND TESTING, IS SOLELY RESPONSIBLE FOR MAKING THE FINAL SELECTION OF THE SYSTEM AND COMPONENTS AND ASSURING THAT ALL PERFORMANCE, ENDURANCE, MAINTENANCE, SAFETY AND WARNING REQUIREMENTS OF THE APPLICATION ARE MET.
- ❖ TO THE EXTENT THAT COXREELS PROVIDE COMPONENT OR SYSTEM OPTIONS BASED UPON DATA OR SPECIFICATIONS PROVIDED BY THE USER, THE USER IS RESPONSIBLE FOR DETERMINING THAT SUCH DATA AND SPECIFICATIONS ARE SUITABLE AND SUFFICIENT FOR ALL APPLICATIONS AND REASONABLY FORESEEABLE USES OF THE COMPONENTS OR SYSTEM.



## WARNING – SAFETY

- ❖ READ ALL SAFETY INSTRUCTIONS CAREFULLY BEFORE ATTEMPTING TO INSTALL, OPERATE, OR MAINTAIN THIS PRODUCT. ONLY QUALIFIED PERSONNEL SHOULD UNDERTAKE THE INSTALLATION AND COMMISSIONING OF THIS PRODUCT. FAILURE TO COMPLY WITH INSTRUCTIONS COULD RESULT IN PERSONAL INJURY AND/OR PROPERTY DAMAGE.
- ❖ FAILURE TO FOLLOW RECOMMENDED APPLICATION INFORMATION AND RECOMMENDED PROCEDURES FOR SELECTION, INSTALLATION, CARE, MAINTENANCE AND STORAGE OF REEL ASSEMBLY, SWIVEL, HOSE, COUPLINGS OR HOSE ASSEMBLIES MAY RESULT IN FAILURE TO PERFORM PROPERLY AND MAY RESULT IN DAMAGE TO PROPERTY AND SERIOUS BODILY INJURY.
- ❖ FOLLOW GOOD MAINTENANCE PRACTICES – ESTABLISH A PROGRAM OF INSPECTION, TESTING AND REPLACEMENT OF REEL COMPONENTS, ACCESSORIES AND OR BRACKETS FROM FACTORS INCLUDING:
  - SEVERITY OF APPLICATION
  - FREQUENCY OF EQUIPMENT USE
  - PAST PERFORMANCE OF REEL COMPONENTS
- ❖ ONLY PROPERLY TRAINED PERSONS SHOULD INSPECT, TEST OR SERVICE REEL AND HOSE/CABLE ASSEMBLIES. PERIODIC UPDATING OF TRAINING IS RECOMMENDED.
- ❖ DOCUMENT MAINTENANCE, INSPECTIONS AND TESTING.

# SAFETY



## PRESSURE WARNINGS

- This equipment should be properly installed before use in accordance with local codes and ordinances.
- PSI warnings not applicable with this series.



## OPERATIONAL WARNINGS

- Exercise care when handling the cable reel during normal operation. These cable reels have a rotating drum that may be powered by a chain, sprocket and gears.
- Do not use cable different from that for which the reel is intended. Changes in diameter, weight per foot, length of cable or flexibility (Minimum Bend Radius) will affect the operation of the reel.
- Mounting hardware and fasteners should be installed to maintain tightness under vibration and checked periodically to ensure tightness.
- Overhead installation mountings should be such that the reel is not supported by bolts in tension. A safety chain, cable, enclosure or netting is strongly recommended to minimize damage and/or possible injury in the event of a mounting failure.



## MAINTENANCE WARNINGS

- Modification of the equipment may cause excessive wear and will void the warranty. Contact COXREELS regarding changes or modifications of equipment which could affect reliability or safety.

800-COX-REEL  
Toll Free Fax: 800-229-REEL  
Email: [info@coxreels.com](mailto:info@coxreels.com)

**SPECIFICATIONS & LISTINGS**

- The identified Series of Cable Reel products within this manual are not certified or listed by any independent certifying or regulatory body.
- This series of cable reels is intended for industrial use and are provided with permanent mounting means, with the exception of the portable reel models.

**PRESSURE & TEMPERATURE RATING**

- All reels covered in this manual with or without cable have specific ratings. (Please refer to the COXREELS catalog, website or contact Customer Service for reel specific data).
- Operational temperature ranges vary across the wide range of cable options. (Please refer to the COXREELS catalog, website or contact Customer Service for hose specific data). Cable reels should not be used at temperatures below or above the rating of the cable.
- The operational rating of a reel not equipped with cable is determined by the capacity of the installed cable. (Please refer to the COXREELS catalog, website or contact Customer Service for reel/hose specific data).

**LABELS & MARKINGS**

Cable Reels with and without cable

- The marking of the cable reel provide with or without cable includes the following
  - The label on the frame includes the COXREELS name and Logo, the product catalog number, the individual product serial number, rating and what type and length of cable intended for use on the reel.
  - The maximum rating for every cable reel supplied without cable is marked on the COXREELS Identification Label. In the absence of this information refer to Coxreels website, catalog, or customer service. Actual rating is determined by the installed cable and is not to exceed the indicated maximum operational rating. The rating of the cable installed on reels provided without cable must be marked on the label upon installation.

**PERSONAL SAFETY**

- Ensure reel has been properly installed before connecting supply line.
- Before connecting to reel, be certain supply line does not exceed voltage / amperage rating on cable reel.
- Thoroughly review the "Cable Installation" instructions to properly install cable.
- Perform "Operational Check" per instructions to ensure reel is operating properly.



**WARNING:** Prevent static sparking. When working around flammables, ensure that the cable reel, cable, and equipment are properly grounded.

## INSTALLATION



**WARNING:** READ THESE INSTRUCTIONS CAREFULLY BEFORE ATTEMPTING TO INSTALL, OPERATE, OR MAINTAIN THIS PRODUCT. ONLY QUALIFIED PERSONNEL SHOULD UNDERTAKE THE INSTALLATION AND COMMISSIONING OF THIS PRODUCT. FAILURE TO COMPLY WITH INSTRUCTIONS COULD RESULT IN PERSONAL INJURY AND/OR PROPERTY DAMAGE.



**WARNING:** REEL SHOULD NOT BE INSTALLED ABOVE 15 FEET MAXIMUM FROM THE FLOOR.

### MOUNTING OF REEL / FASTEN CRANK HANDLE

- 1) The 1125PC Series power cord reel should be mounted to a solid structure before installation of cord and operation using appropriate bolts, nuts, and washers (not included).
- 2) Hand crank reels are supplied with plastic crank handle uninstalled. Remove handle and supplied hardware from plastic bag and install onto crank arm.

### INSTALLATION OF INLET CORD

- 1) Remove reel drum access covers to allow easy access to slip ring assembly and electrical connections.
- 2) Inlet cord is most easily installed with the slip ring assembly removed from the reel. To remove the slip ring assembly from the reel, loosen the two set screws that hold the slip ring assembly on the axle as shown in **Figure 2**.
- 3) Route cord through cord grip and reel axle and into center drum. Strip back enough cord to allow conductors to easily fit through center of slip ring assembly.
- 4) Connect inlet cord to slip ring wires marked 1 through 3 with appropriate sized wire nuts or other suitable connectors. Make connections as short as possible to avoid interference with rotating parts (see **Figure 1**).
- 5) By convention, wire and terminal #1 is for black conductor, wire and terminal #2 is for green (or ground) conductor, and wire and terminal #3 is for white conductor. Make note of each wire and terminal number's corresponding wire color.
- 6) Reinstall slip ring assembly and inlet cord through the slip ring axle on reel while pulling inlet cord through inlet cord grip.
- 7) The slip ring mounting plate has a cutout, which must be aligned to the slip ring drive screw (see **Figure 2**), to properly operate slip ring assembly.



- 8) Tighten set screws on slip ring assembly to slip ring axle and tighten inlet cord grip around inlet cord.
- 9) Check operation by rotating reel by hand to ensure no binding or twisting of cable or wire occurs around slip ring and inside reel drum.
- 10) The cord keeper will help prevent inlet cord rotation during reel operation (see **Figure 1**).

### INSTALLATION OF OUTLET CORD

**NOTE:** Before proceeding, ensure that you are installing the proper size, length and type of cord that the reel is rated for. Consult factory if unsure of rating. Damage may occur if wrong cord and/or length is installed.

- 1) Securely stabilize the reel.
- 2) Fasten the cord to the slip ring assembly with suitable ring terminals as shown in **Figure 3**.
- 3) To properly ground reel, attach a ground wire from the ground terminal (should be terminal #2, green), to slip ring drive screw using suitable ring terminals as shown in **Figure 2**.
- 4) Tighten cord grip around outlet cord onto reel and re-install drum access covers onto reel.
- 5) Wrap cord onto reel using proper size and length.

### HOOK-UP ELECTRICAL MOTOR

**⚠ CAUTION: REMOVE ALL ELECTRICAL POWER WHEN WIRING. DO NOT HOT WIRE. OBSERVE ALL APPLICABLE NEC, OSHA, AND LOCAL CODES.**

- 1.) Ensure motor location is conducive to mounting or operating requirements. Field modifications are not recommended.
- 2.) Ensure power supply and motor voltage ratings are compatible. Refer to figures 5, 6, and 7 for wiring diagrams.
- 3.) Install switch, solenoid, circuit breaker, etc. as required. Consult factory for optional components.
- 4.) Apply power, and inspect reel to determine proper operation.
- 5.) To change motor direction on 115-VAC motors, exchange wires #5 and #6.

### HOOK-UP AIR MOTOR

**⚠ CAUTION: DO NOT EXCEED 100 PSI MOTOR INLET PRESSURE. USE AN FRL OR CONTROL VALVE (IN LINE) TO ADJUST SPEED.**

- 1) A suitable sized filter/regulator/lubricator must be installed in the compressed air line within 3-6 ft. from the motor.
- 2) Use pipes that are the same size as the motor ports for lengths up to 6 ft. from the main line and pipes that are larger for lengths that are longer than 6 ft. Remove plastic plugs from two ports in motor and follow steps 3 or 4 for installation.
- 3) A muffler (provided) must be connected to the outlet port on single rotation applications. A 3-way air valve (not included) should be used on single direction applications.
- 4) A 4-way valve (not included) may be used to drive reel in both directions by being connected to both ports of the motor. A muffler must then be connected to the air outlet pipe or valve port.
- 5) Do not use thread tape to seal pipe threads. Use only the correct pipe sealant on the threads.
- 6) This motor requires LUBRICATION. Use GAST lubricating oil part number UK5220 or equivalent. Fill reservoir to correct level.
- 7) Apply air pressure, and inspect reel to determine proper operation.

### OPERATIONAL CHECK

- 1) Check for correct operation by pulling out some of the cord. A slight friction or drag should be noticed. This drag is to prevent backlash when pulling out cord and help prevent uncoiling of cord during transport on hand crank model reels.
- 2) Adjust drag brake (Hand crank models only). Turn clockwise to increase tension and counter-clockwise to decrease tension. See **Figure 4**.

### ● SLIP RING REPLACEMENT

- 1) Remove cord completely from drum of reel.
- 2) Remove slip ring access covers from reel drum.
- 3) Loosen cord grip on input and output cords.
- 4) Loosen slip ring set screws as shown in **Figure 2**.
- 5) Disconnect inlet and output cords and remove slip ring assembly.
- 6) Install new slip ring assembly and input cord per procedure in "INSTALLATION OF INLET CORD" section.
- 7) Install output cord per procedure in "INSTALLATION OF OUTPUT CORD" section.

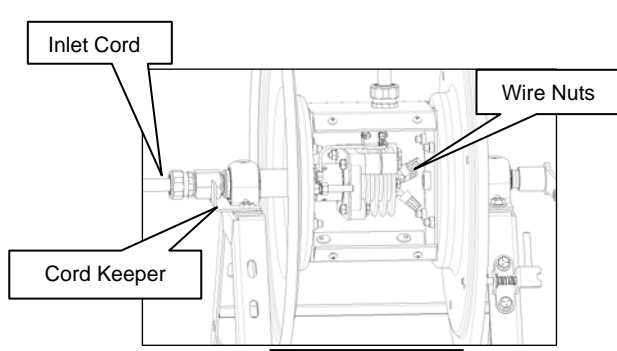

Figure 1

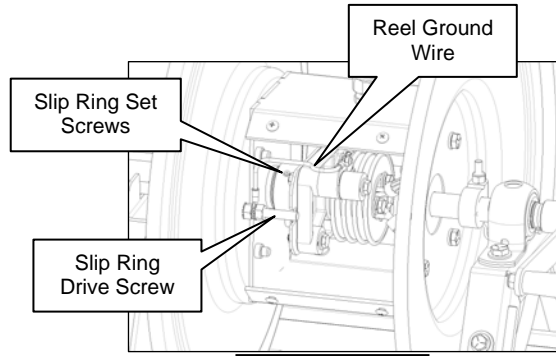

Figure 2

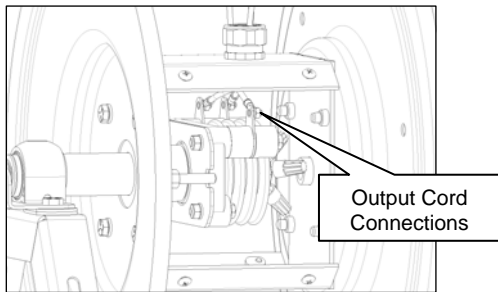

Figure 3

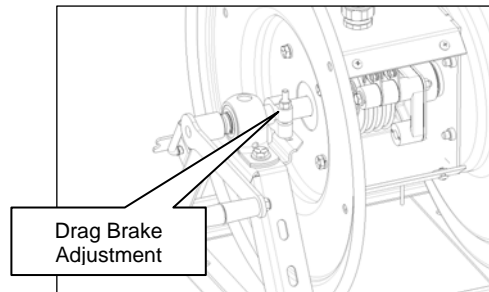

Figure 4 – Hand Crank Models Only

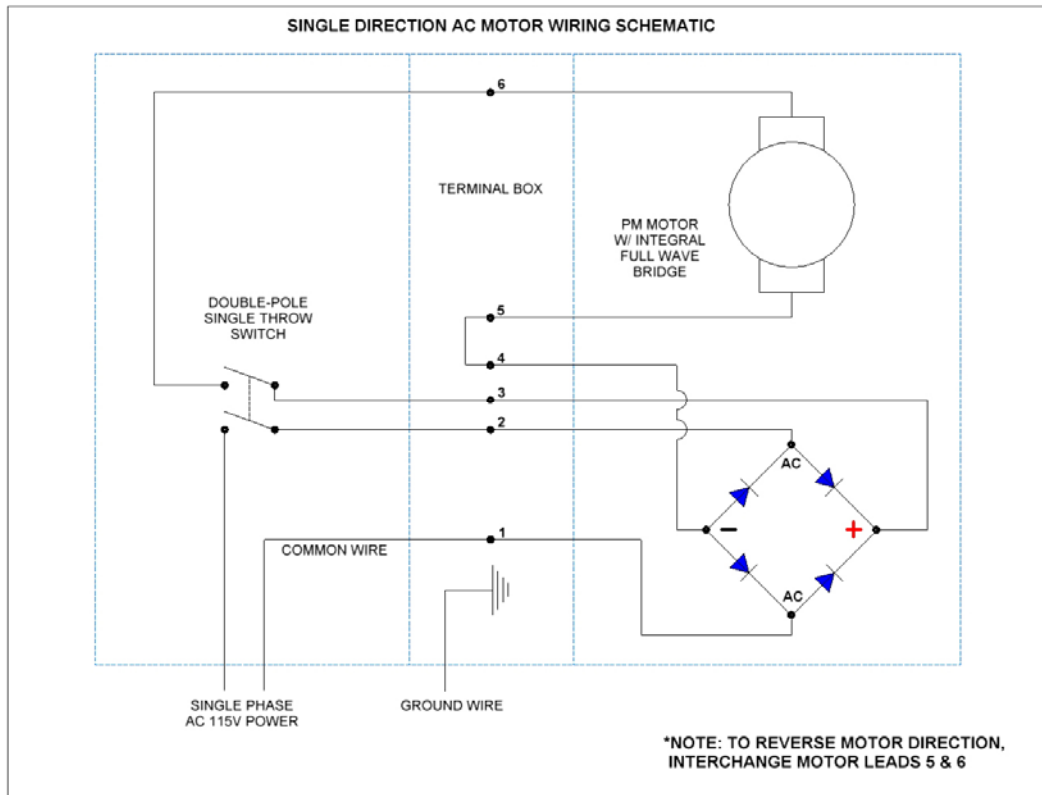

Figure 5: 115-VAC "EA" Motor Option, Single Direction

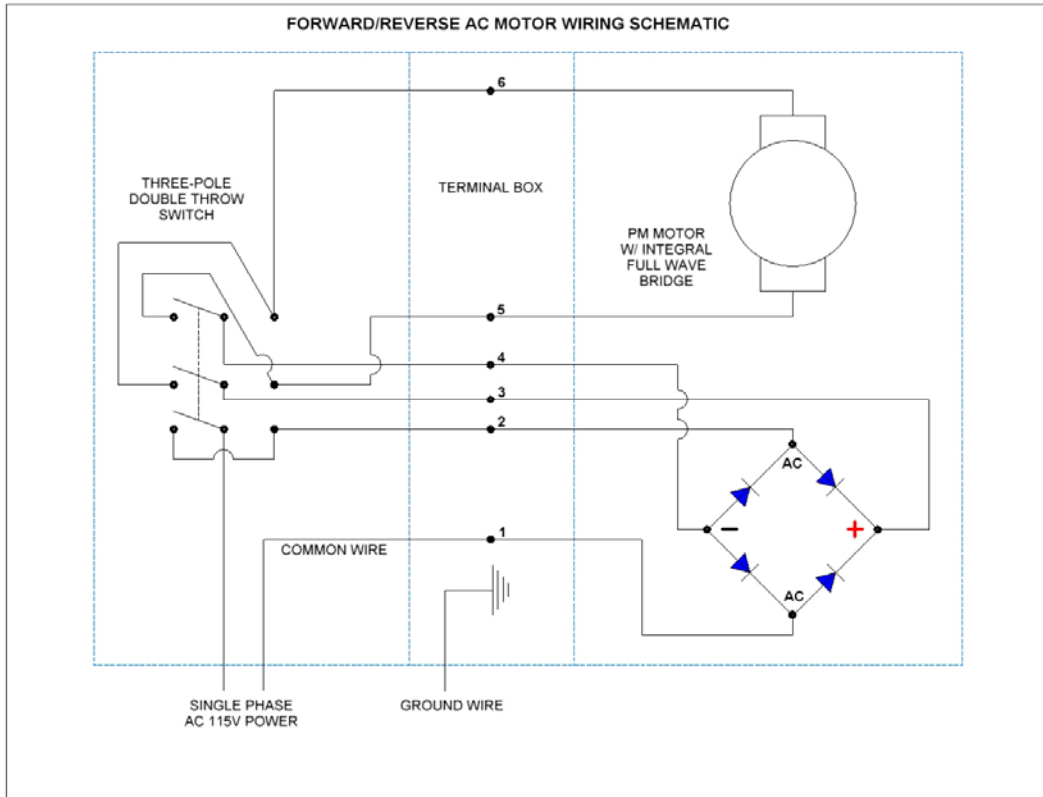

Figure 6: 115-VAC "EA" Motor Option, Dual Direction

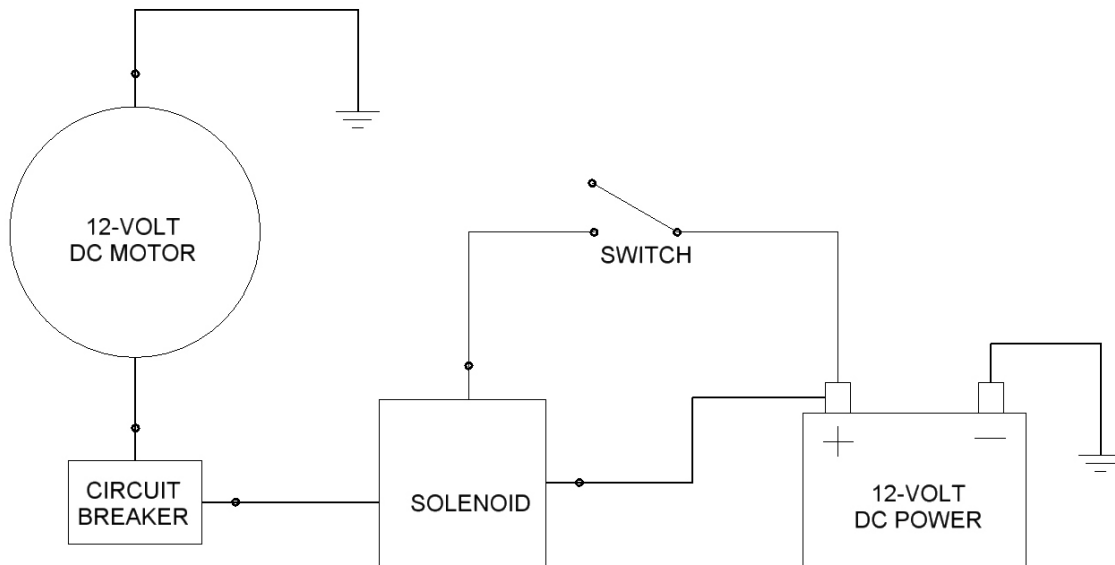

Figure 7: 12-VDC "E" & "ED" Motor Option

**TROUBLE SHOOTING GUIDE**



TROUBLE	CAUSE	REMEDY
CORD WILL NOT FULLY FIT ONTO DRUM OF REEL	a) Cord is longer than specified. b) Outside diameter of cord is larger than specified capacity. c) Cord was not hand guided onto reel and wound up evenly on drum.	a) Cut down cord length to meet reels specified capacity. b) Replace cord with one that meets specified maximum outside diameter requirements. c) Hand guide cord onto drum as it is wound onto the reel.
REEL KEEPS TURNING WHEN OPERATOR STOPS PULLING OUT CORD	Tension drag brake is too loose causing cord backlash	Adjust tension drag brake by turning knob clockwise.
NO ELECTRICAL CURRENT AT OUTPUT END OF CORD	a) Cord is severed b) Slip ring brushes are worn	a) Replace cord b) Replace slip ring c) Note: ensure current does not exceed rated amperage.
IT IS VERY DIFFICULT TO PULL CORD OFF REEL ON 115-AC-V MOTORIZED REEL	Incorrect motor wiring	Refer to wiring diagram and ensure proper switch type and wiring are used.
IT IS VERY DIFFICULT TO PULL CORD OFF REEL ON PNEUMATIC MOTORIZED REEL	Air is not able to move freely through control valve during uncoiling.	Use a 3-Way air valve on single direction applications

** WARNING:**

Use extreme caution when operating or servicing electrical cable reels. Personal injury or death can occur even under low voltage! Only qualified service technicians should troubleshoot and repair these products.

Observe all applicable NEC, OSHA, and local codes when operating or installing these products.

For assembly drawings, parts lists, or specific repair instructions, refer to web site at [www.coxreels.com](http://www.coxreels.com) or consult factory.

Coxreels, Inc., 6720 S. Clementine Ct., Tempe, Arizona, USA, 85283 Tel: 1-800-269-7335