

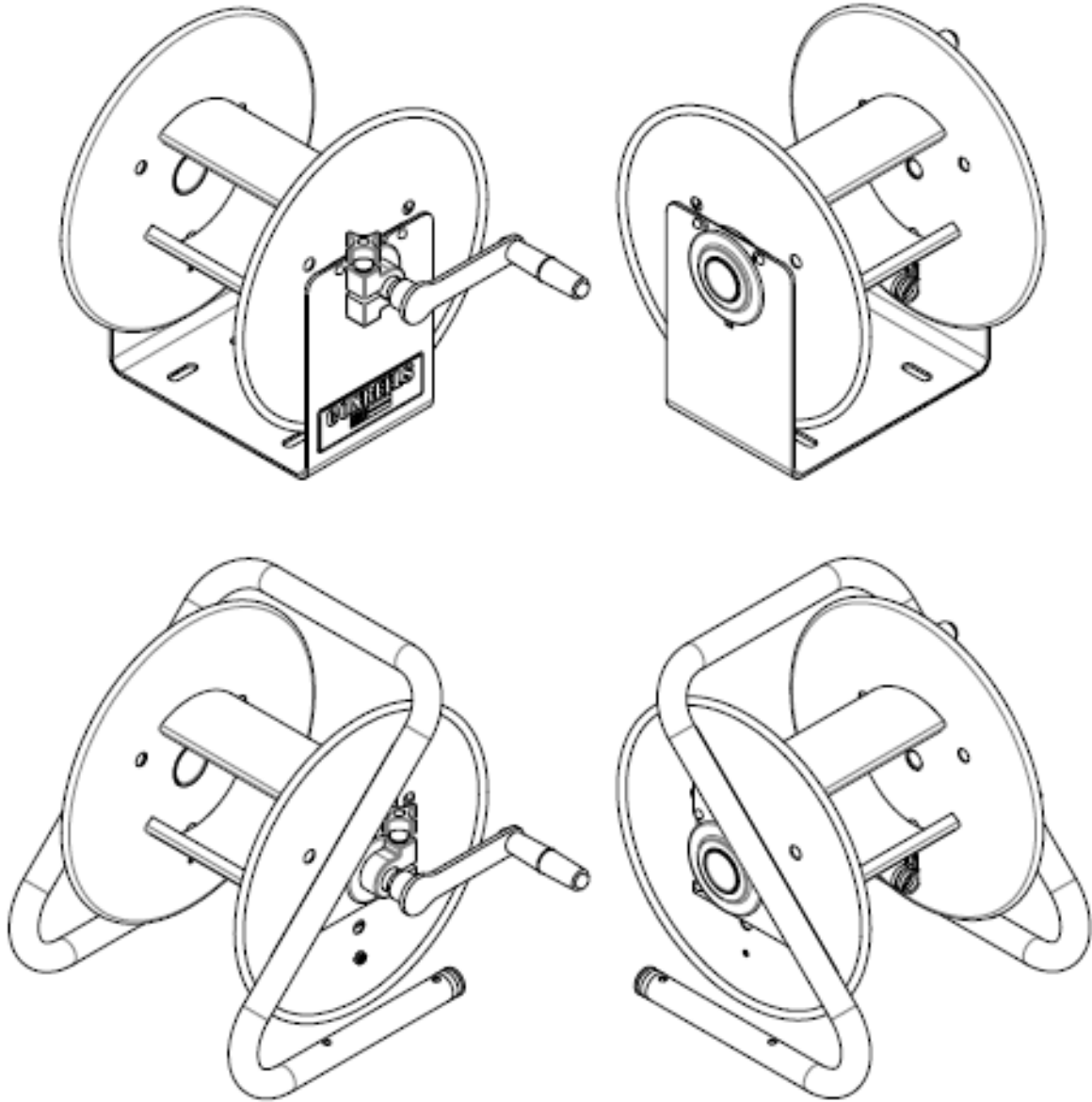

CHALLENGER/CADDY MOUNT HOSE
AND CABLE STORAGE REEL





COXREELS

The technical data and images which appear in this manual are for informational purposes only. **NO WARRANTIES, EXPRESS OR IMPLIED, INCLUDING WARRANTIES OF MERCHANTABILITY OR FITNESS FOR A PARTICULAR PURPOSE, ARE CREATED BY THE DESCRIPTIONS AND DEPICTIONS OF THE PRODUCTS SHOWN IN THIS MANUAL.** COXREELS makes no warranty (and assumes no liability) as to function of equipment or operation of systems built according to customer design or of the ability of any of its products to interface, operate or function with any portions of customer systems not provided by COXREELS.

COXREELS agrees to repair or exchange the goods sold hereunder necessitated by reason of defective workmanship and material discovered and reported to COXREELS within two years after original invoice date.

Except where the nature of the defect is such that it is appropriate, in COXREELS' judgment, to effect repairs on site, COXREELS' obligation hereunder to remedy defects shall be limited to repairing or replacing (at COXREELS' option) FOB COXREELS Factory, any part returned to COXREELS at the risk and cost of Buyer. Defective parts replaced shall become the property of COXREELS.

COXREELS shall only be obligated to make such repair or replacement if the goods have been used by Buyer only in service recommended. COXREELS is not responsible for defects which arise from improper installation, neglect, improper use of or from normal wear and tear.

COXREELS obligation shall be limited by the manufacturer's warranty (and is not further warranted by COXREELS) for all parts procured from others according to published data, specifications or performance information not designed by COXREELS.

COXREELS further agrees to replace or at COXREELS' option to provide a refund of the sales price of any goods that do not conform to applicable specifications or which differ from that agreed to be supplied which non-conformity is discovered and forthwith reported to COXREELS within 30 days after shipment to the Buyer. COXREELS' obligation to replace or refund the purchase price for non-conforming goods shall arise once the Buyer returns such goods FOB COXREELS Factory at the risk and cost of Buyer. Goods replaced by COXREELS shall become property of COXREELS.

COXREELS liability on any claim, whether in contract, tort (including negligence), or otherwise, for any loss or damage arising out of, connected with, or resulting from the manufacture, sale, delivery, resale, repair, replacement or use of any products or services shall in no case exceed the price paid for the product or services or any part thereof which give rise to the claim. In no event shall COXREELS be liable for consequential, special, incidental or other damages, nor shall COXREELS be liable in respect of personal injury or damage to property not the subject matter hereof unless attributable to gross misconduct of COXREELS, which shall mean an act or omission by COXREELS demonstrating reckless disregard of the foreseeable consequences thereof.

COXREELS is not responsible for incorrect choice of models or where products are used in excess of their rated and recommended capacities and design functions or under abnormal conditions. COXREELS assumes no liability for loss of time, damage or injuries to property or persons resulting from the use of COXREELS products. Buyer shall hold COXREELS harmless from all liability, claims, suits and expenses in connection with loss or damage resulting from operation of products or utilization of services, respectively, of COXREELS and shall defend any suit or action which might arise there from in Buyer's name – provided that COXREELS shall have the right to elect to defend any such suit or action for the account of Buyer. The foregoing shall be the exclusive remedies of the Buyer and all persons and entities claiming through the Buyer.

NOTE: All designs, specifications, and dimensional data contained in this publication are subject to change without notice.



WARNING – APPLICATION

- ❖ THE PRODUCTS IN THIS INSTALLATION AND MAINTENANCE MANUAL HAVE BEEN TESTED UNDER CONTROLLED LABORATORY CONDITIONS TO MEET SPECIFIC TEST CRITERIA. THESE TESTS ARE NOT INTENDED TO REFLECT THE PERFORMANCE OF THE PRODUCTS OR ANY OTHER MATERIAL IN ANY SPECIFIC APPLICATION, BUT ARE INTENDED TO PROVIDE THE USER WITH APPLICATION GUIDELINES. THE PRODUCTS ARE INTENDED FOR USE BY KNOWLEDGEABLE PERSONS HAVING THE TECHNICAL SKILL NECESSARY TO EVALUATE THEIR SUITABILITY FOR SPECIFIC APPLICATIONS.



WARNING – USER RESPONSIBILITY

- ❖ THE USER, THROUGH ITS OWN ANALYSIS AND TESTING, IS SOLELY RESPONSIBLE FOR MAKING THE FINAL SELECTION OF THE SYSTEM AND COMPONENTS AND ASSURING THAT ALL PERFORMANCE, ENDURANCE, MAINTENANCE, SAFETY AND WARNING REQUIREMENTS OF THE APPLICATION ARE MET.
- ❖ TO THE EXTENT THAT COXREELS PROVIDE COMPONENT OR SYSTEM OPTIONS BASED UPON DATA OR SPECIFICATIONS PROVIDED BY THE USER, THE USER IS RESPONSIBLE FOR DETERMINING THAT SUCH DATA AND SPECIFICATIONS ARE SUITABLE AND SUFFICIENT FOR ALL APPLICATIONS AND REASONABLY FORESEEABLE USES OF THE COMPONENTS OR SYSTEM.



WARNING – SAFETY

- ❖ READ ALL SAFETY INSTRUCTIONS CAREFULLY BEFORE ATTEMPTING TO INSTALL, OPERATE, OR MAINTAIN THIS PRODUCT. ONLY QUALIFIED PERSONNEL SHOULD UNDERTAKE THE INSTALLATION AND COMMISSIONING OF THIS PRODUCT. FAILURE TO COMPLY WITH INSTRUCTIONS COULD RESULT IN PERSONAL INJURY AND/OR PROPERTY DAMAGE.
- ❖ FAILURE TO FOLLOW RECOMMENDED APPLICATION INFORMATION AND RECOMMENDED PROCEDURES FOR SELECTION, INSTALLATION, CARE, MAINTENANCE AND STORAGE OF REEL ASSEMBLY, SWIVEL, HOSE, COUPLINGS OR HOSE ASSEMBLIES MAY RESULT IN FAILURE TO PERFORM PROPERLY AND MAY RESULT IN DAMAGE TO PROPERTY AND SERIOUS BODILY INJURY.
- ❖ FOLLOW GOOD MAINTENANCE PRACTICES – ESTABLISH A PROGRAM OF INSPECTION, TESTING AND REPLACEMENT OF REEL COMPONENTS, ACCESSORIES AND OR BRACKETS FROM FACTORS INCLUDING:
 - SEVERITY OF APPLICATION
 - FREQUENCY OF EQUIPMENT USE
 - PAST PERFORMANCE OF REEL COMPONENTS
- ❖ ONLY PROPERLY TRAINED PERSONS SHOULD INSPECT, TEST OR SERVICE REEL AND HOSE/CABLE ASSEMBLIES. PERIODIC UPDATING OF TRAINING IS RECOMMENDED.
- ❖ DOCUMENT MAINTENANCE, INSPECTIONS AND TESTING.

**SAFETY****PRESSURE WARNINGS**

- This equipment should be properly installed before use in accordance with local codes and ordinances.
- The pressure to and from the hose reel should be released and disconnected from the hose reel before any service functions are performed.
- This hose reel must not be used for pressure greater than the rating listed in the COXREELS catalog / website www.coxreels.com.

**OPERATIONAL WARNINGS**

- Exercise care when handling the hose reel during normal operation.
- Do not use hose different from that for which the reel is intended. Changes in diameter, weight per foot, length of hose or flexibility (Minimum Bend Radius) will affect the operation of the reel.
- Mounting hardware and fasteners should be installed to maintain tightness under vibration and checked periodically to ensure tightness.
- Overhead installation mountings should be such that the reel is not supported by bolts in tension. A safety chain, cable, enclosure or netting is strongly recommended to minimize damage and/or possible injury in the event of a mounting failure.

**MAINTENANCE WARNINGS**

- Modification of the equipment may cause excessive wear and will void the warranty. Contact COXREELS regarding changes or modifications of equipment which could affect reliability or safety.

800-COX-REEL
Toll Free Fax: 800-229-REEL
Email: info@coxreels.com

**SPECIFICATIONS & LISTINGS**

- The identified Series of Hose Reel products within this manual are not certified or listed by any independent certifying or regulatory body.
- This series of hose reels is intended for industrial use and are provided with permanent mounting means, with the exception of the portable reel models.

**PRESSURE & TEMPERATURE RATING**

- All reels covered in this manual with or without hose have specific P.S.I. ratings. (Please refer to the COXREELS catalog, website or contact Customer Service for reel specific data). Reels should not be used at pressures greater than the rating of the hose, swivel, plumbing or overall reel rating.
- Multipurpose hose is installed with tube compounded for maximum oil resistance. Hose can be used for air, water, oil and many other chemical applications.
- Operational temperature ranges vary across the wide range of hose options. (Please refer to the COXREELS catalog, website or contact Customer Service for hose specific data). Hose reels should not be used at temperatures below or above the rating of the hose.
- The operational rating of a reel not equipped with hose is determined by the capacity of the installed hose. The pressure rating of the reel without hose must not be greater than the operational capacity of a reel. (Please refer to the COXREELS catalog, website or contact Customer Service for reel/hose specific data). Variations in the OD of higher rated hose will affect the operational capacity of the reel.

**LABELS & MARKINGS**

Hose Reels with and without hose

- The marking of the hose reel provide with or without hose includes the following:
 - The label on the frame includes the COXREELS name and Logo, the product catalog number, the individual product serial number, PSI rating and what type and length of hose intended for use on the reel.
 - The maximum pressure rating for every hose reel supplied without hose is marked on the COXREELS Identification Label. Actual rating is determined by the installed hose and is not to exceed the indicated maximum operational rating. The pressure rating of the hose installed on reels provided without hose must be marked on the label upon installation.



NOTE: If for any reason the information is not included or the label has become illegible, please refer to the COXREELS catalog, website or contact Customer Service for reel specific data.

**PERSONAL SAFETY**

- Ensure reel has been properly installed before connecting supply line.
- Before connecting to reel, be certain supply line does not exceed rated pressure of the hose reel or voltage / amperage rating on cable reel.
- Thoroughly review the "Hose Installation" instructions to properly install hose.
- Perform "Operational Check" per instructions to ensure reel is operating properly.
- If a leak should occur after applying pressure to the reel, immediately turn off pressure source and discontinue supply line pressure.



WARNING: Prevent static sparking. When working around flammables, ensure that the hose reel, hose, and equipment are properly grounded.

INSTALLATION

 **WARNING:** READ THESE INSTRUCTIONS CAREFULLY BEFORE ATTEMPTING TO INSTALL, OPERATE, OR MAINTAIN THIS PRODUCT. ONLY QUALIFIED PERSONNEL SHOULD UNDERTAKE THE INSTALLATION AND COMMISSIONING OF THIS PRODUCT. FAILURE TO COMPLY WITH INSTRUCTIONS COULD RESULT IN PERSONAL INJURY AND/OR PROPERTY DAMAGE.

 **WARNING:** REEL SHOULD NOT BE INSTALLED ABOVE 15 FEET MAXIMUM FROM THE FLOOR.

PERSONAL SAFETY

- Ensure reel has been properly installed before routing cable/supply line.
- Before routing through reel, be certain supply line does not exceed rated pressure.
- Thoroughly review the section: "Installation of Extension Cable/Hose" instructions to properly install hose.
- If a leak should occur after applying pressure to the reel, immediately discontinue supply line pressure.
- Ensure that the cable or hose is disconnected at both ends before attempting to wind it back onto the reel.

MOUNTING OF REEL

- The 112Y-Series hose/cable extension reel has been designed to attach horizontally to a bench top, upside down underneath a bench top, or vertically along a wall or beam. It is not necessary to install the Caddy Mount style.
- The reel base is equipped with four mounting holes to utilize 3/8" diameter hardware (Challenger style) or 1/4" diameter hardware (Caddy Mount). Hardware is not included.

INSTALLATION OF EXTENSION CABLE/HOSE

 **NOTE:** Before proceeding, ensure that you are installing the proper size, length and type of hose that the reel is rated for. Consult factory if unsure of rating. Damage may occur if wrong hose and/or length are installed.

- Route the cable/hose through the gap in the drum and out of the axle on the non-handle side of the reel.
- Select a length for the amount of cable/hose that you wish to leave as the connector. This amount will not be wound onto the drum but will exit out of the axle and must be able to be pushed inside of the drum. Any amount of cable/hose not able to be pushed into the drum may lash around when winding/unwinding the reel. **(See Fig 1.0)**
- Use one of the enclosed clamps to secure the cable/hose to the disc on the handle side. **(See Fig 1.1)** The sizes of the clamps, Coxreels® part numbers, and correlating cable/hose sizes are shown. **(Chart 1.0)**

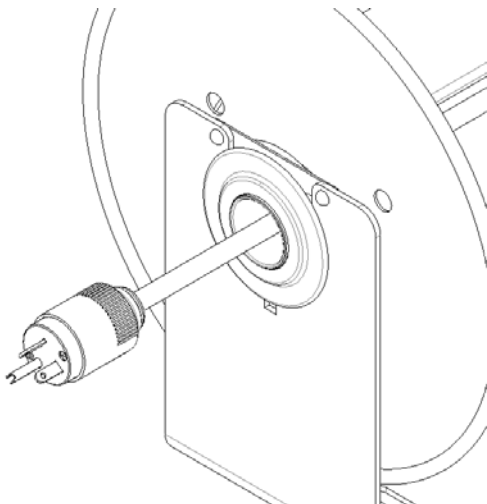

FIGURE 1.0

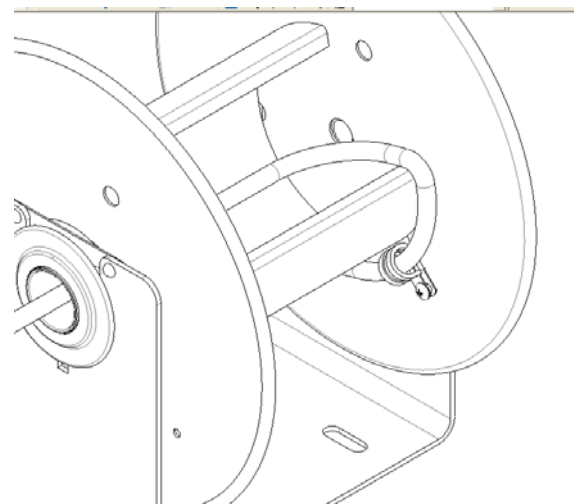

FIGURE 1.1



7199-1(Smallest):	16/3 CABLE
7199(2 nd Smallest):	12/3 CABLE
381(2 nd Largest):	10/3 CABLE, 3/8" ID HOSE
383(Largest):	1/2" ID HOSE

CHART 1.0

OPERATIONAL CHECK

- Check for correct operation by pulling out some of the hose/cable. A slight friction or drag should be noticed. This drag is to prevent backlash when pulling out hose/cable.
- Adjust the drag brake. Turn clockwise to add tension and counter-clockwise to decrease tension. See figure 2.0

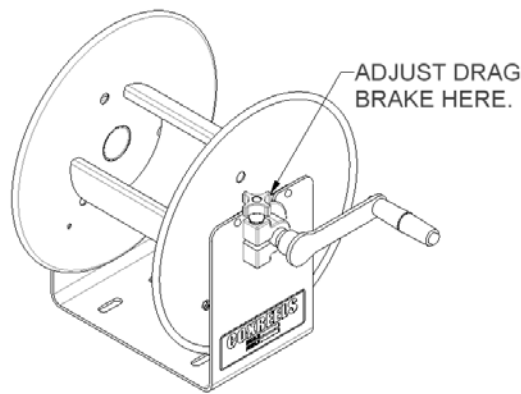



FIGURE 2.0

USEAGE

 **NOTE:** Before proceeding, ensure that you are installing the proper size, length and type of hose that the reel is rated for. Consult factory if unsure of rating. Damage may occur if wrong hose and/or length are installed.

- Ensure that both ends of the cable/hose are disconnected before attempting to wind or unwind.
- Once disconnected, the shorter, connection end can be pushed inside of the drum to make for easier carrying (Caddy Mount) and to prevent the cord from twisting when winding/unwinding.
- To use, unroll cable/hose to desired length and connect to source and destination.