

EXP-160

REVISION: C

ECO NO.: 1801-6

DRAWN BY: J. KNOSALLA

DATE: 11/19/01

COXREELS
600 SERIES

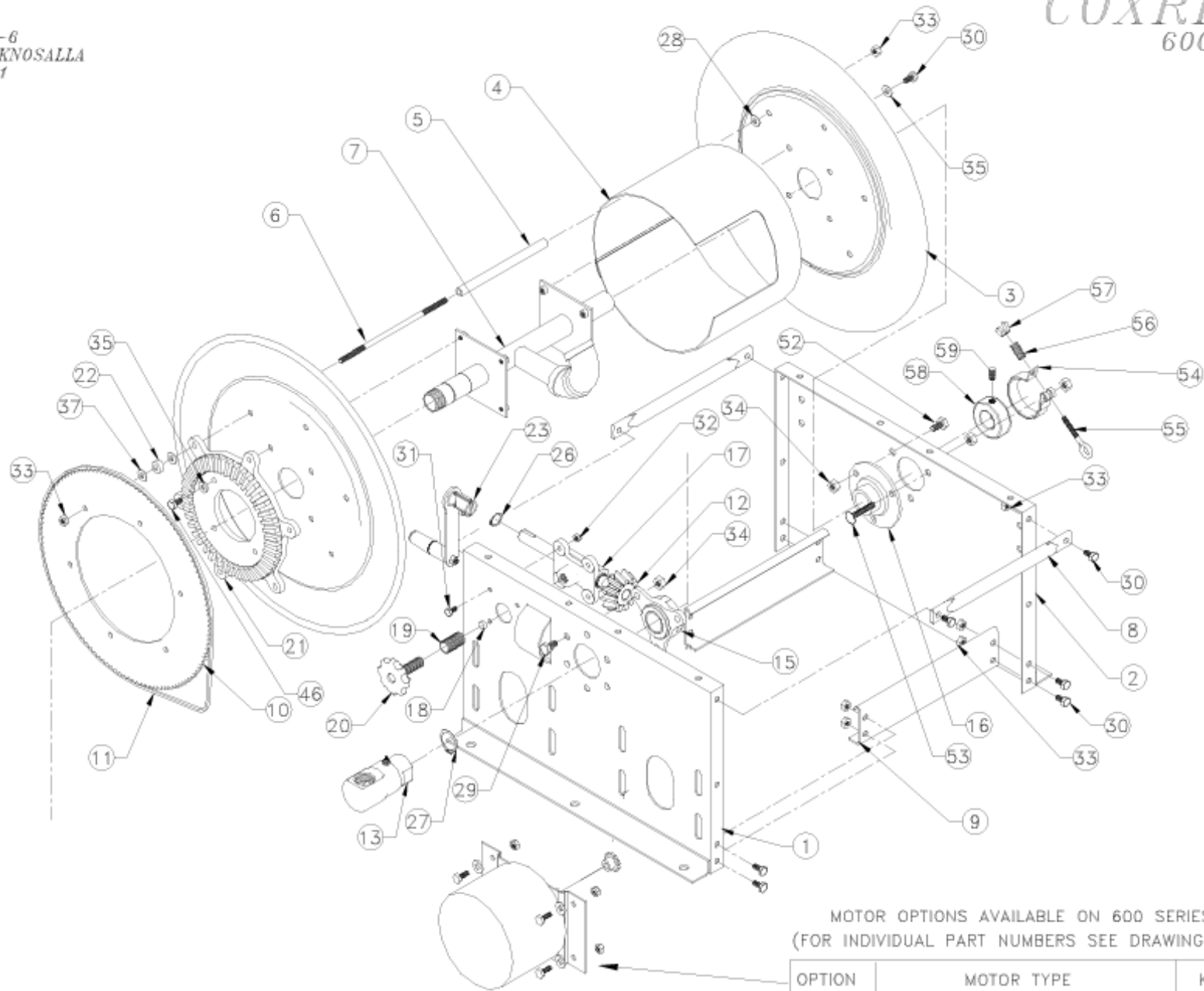

MOTOR OPTIONS AVAILABLE ON 600 SERIES REELS
(FOR INDIVIDUAL PART NUMBERS SEE DRAWING # CM-600)

OPTION	MOTOR TYPE	KIT NUMBER
-A	AIR	CM-600-A
-EA	115VAC ELECTRIC, EXPL PROOF	CM-600-EA
-ED	12VDC ELECTRIC, EXPL PROOF	CM-600-ED
-E	12VDC ELECTRIC	CM-600-E
-H	HYDRAULIC	CM-600-H

ITEM	PART	DESCRIPTION	600-1320-	600-2020-	600-3320-	600-724-	600-1324	600-2024-	600-3324-	600-728-	600-1328-	600-2028-	600-3328-
1	20226	ASSY, PANEL, SWIVEL, 20"	1	1	1	*	*	*	*	*	*	*	*
1	20232	ASSY, PANEL, SWIVEL, 24"	*	*	*	1	1	1	1	*	*	*	*
1	20238	ASSY, PANEL, SWIVEL, 28"	*	*	*	*	*	*	*	1	1	1	1
2	20222	ASSY, PANEL, SPRING, 20"	1	1	1	*	*	*	*	*	*	*	*
2	20228	ASSY, PANEL, SPRING, 24"	*	*	*	1	1	1	1	*	*	*	*
2	20234	ASSY, PANEL, SPRING, 28"	*	*	*	*	*	*	*	1	1	1	1
3	15006-2	DISC, 20"	2	2	2	*	*	*	*	*	*	*	*
3	20585-2	DISC, 24"	*	*	*	2	2	2	2	*	*	*	*
3	20587-2	DISC, 28"	*	*	*	*	*	*	*	2	2	2	2
4	20251-7.5	DRUM, 10-1/2"	*	*	*	1	*	*	*	1	*	*	*
4	20251-13.5	DRUM, 10-1/2"	1	*	*	*	1	*	*	*	1	*	*
4	20251-20	DRUM, 10-1/2"	*	1	*	*	*	1	*	*	*	1	*
4	20251-33	DRUM, 10-1/2"	*	*	1	*	*	*	1	*	*	*	1
5	20275-7.5	SPACER, DRUM SUPPORT	*	*	*	6	*	*	*	6	*	*	*
5	20275-13.5	SPACER, DRUM SUPPORT	6	*	*	*	6	*	*	*	6	*	*
5	20275-20	SPACER, DRUM SUPPORT	*	6	*	*	*	6	*	*	*	6	*
5	20275-33	SPACER, DRUM SUPPORT	*	*	6	*	*	*	6	*	*	*	6
6	20268-7.5	ROD, DRUM SUPPORT	*	*	*	6	*	*	*	6	*	*	*
6	20268-13.5	ROD, DRUM SUPPORT	6	*	*	*	6	*	*	*	6	*	*
6	20268-20	ROD, DRUM SUPPORT	*	6	*	*	*	6	*	*	*	6	*
6	20268-33	ROD, DRUM SUPPORT	*	*	6	*	*	*	6	*	*	*	6
7	20930-7.5	ASSY, AXLE, PLUMBING, 1"	*	*	*	1	*	*	*	1	*	*	*
7	20930-13.5	ASSY, AXLE, PLUMBING, 1"	1	*	*	*	1	*	*	*	1	*	*
7	20930-20	ASSY, AXLE, PLUMBING, 1"	*	1	*	*	*	1	*	*	*	1	*
7	20930-33	ASSY, AXLE, PLUMBING, 1"	*	*	1	*	*	*	1	*	*	*	1
8	20244-7.5	TUBE, TOP SPACER	*	*	*	2	*	*	*	2	*	*	*
8	20244-13.5	TUBE, TOP SPACER	2	*	*	*	2	*	*	*	2	*	*
8	20244-20	TUBE, TOP SPACER	*	2	*	*	*	2	*	*	*	2	*
8	20244-33	TUBE, TOP SPACER	*	*	2	*	*	*	2	*	*	*	2
9	20385-7.5	RAIL, BOTTOM SPACER	*	*	*	2	*	*	*	2	*	*	*
9	20385-13.5	RAIL, BOTTOM SPACER	2	*	*	*	2	*	*	*	2	*	*
9	20385-20	RAIL, BOTTOM SPACER	*	2	*	*	*	2	*	*	*	2	*
9	20385-33	RAIL, BOTTOM SPACER	*	*	2	*	*	*	2	*	*	*	2
10	20394	SPROCKET	**	1	1	1	*	*	*	*	*	*	*
10	20502-10	SPROCKET	**	*	*	*	1	1	1	*	*	*	*
10	20500	SPROCKET	**	*	*	*	*	*	*	1	1	1	1
11	20396	ASSY, CHAIN	**	1	1	1	*	*	*	*	*	*	*
11	20397	ASSY, CHAIN	**	*	*	*	1	1	1	*	*	*	*
11	20398	ASSY, CHAIN	**	*	*	*	*	*	*	1	1	1	1
12	20426-20	ASSY, PINION GEAR	1	1	1	*	*	*	*	*	*	*	*
12	20426-24	ASSY, PINION GEAR	*	*	*	1	1	1	1	*	*	*	*
12	20426-28	ASSY, PINION GEAR	*	*	*	*	*	*	*	1	1	1	1

600 SERIES (COMMON TO ALL MODELS)

600 SERIES (WITH MOTOR)

600 SERIES (WITH CRANK)

ITEM	PART	QTY	
13	15257-1	ASSY, SWIVEL, 1"	1
15	20996	ASSY, BEARING HOUSING	1
16	20300	ASSY, BEARING	1
27	15012	RETAINING RING	1
28	20294	NUT, SELF LOCKING, 5/16	6
29	20016	BOLT, 3/8-16 X 1"	3
30	312	BOLT, 5/16-18 X 3/4"	16
33	111	NUT, LOCK, 5/16-18	24
34	435	NUT, LOCK, 3/8-16	6
35	112	WASHER, LOCK, 5/16	8
52	436	BOLT, 3/8-16X3/4"	3

ITEM	PART	QTY	
22	16017-1	SPACER, SPROCKET	6
53	10238	BOLT, CRGE, 3/8 X 2"	1
54	6378	BAND, BRAKE	1
55	6379	BOLT, EYE, 1/4-20	1
56	6381-SS	SPRING, COMP	1
57	6380	NUT, WING, 1/4-20	1
58	6375	DRUM, BRAKE	1
59	10235-1	SCREW, SET, 3/8 X 1/2"	1

<QTY 20 IF MOTOR/NO CRANK)

<QTY 2 IF MOTOR/NO CRANK)

ITEM	PART	QTY	
17	20325	ASSY, BEARING	1
18	15173	BRAKE PAD	1
19	15205	SPRING BREAK	1
20	20295	ASSY, BRAKE KNOB	1
21	20330	GEAR, BEVEL	1
22	16017	SPACER, NYLON	6
23	20420	ASSY, OFFSET CRK	1
26	20326	RETAINING RING	2
31	3030	BOLT, 1/4-20 X 3/4"	4
32	125	NUT, KEPS, 1/4-20	4
37	20171	WASHER, FLAT, 5/16	12
46	169	BOLT, 5/16-18 X 1"	4

** THIS ITEM IS NOT SUPPLIED WITH HAND CRANK ONLY MODELS (NO -C SUFFIX IN MODEL NUMBER) *** THIS ITEM IS SUPPLIED WITH HAND CRANK "ONLY" MODELS (-C SUFFIX IN MODEL NUMBER)