

HOSE, CORD & CABLE REELS

Construction

COXREELS SINCE 1923



INDUSTRY CATALOG



CONSTRUCTION REELS



IT'S NOT JUST A LABEL,

IT'S A BADGE OF HONOR

Hose, cord, and cable reels are essential components on building residential, commercial, or repairing and maintaining equipment. Reels are the preferred choice for managing hoses or neatly and conveniently storing them.

The Recognized Industry Leader

Coxreels is wholesale only since 1923. Our product is made to high standards, supplying industrial grade product to distributors and OEMs worldwide. We are recognized as the leader in the reeling industry. We have been providing the most complete and diverse line of hose, cord, and cable reels for 10 decades!

The Most Complete Line of Construction Reels in the Market

Contractors and construction workers cannot expect less out of the reels they so heavily rely on. Whether you are building residential, commercial, or repairing and maintaining equipment – we got you covered!

Our wide array of standard and custom built reeling solutions are designed and tested to back your needs in the field of construction with everything from excavation, foundation, and concrete; utilities (sewer, electrical, water, and gas); to framing, sheathing, roofing, and plumbing.

Proven reeling solutions to Construction needs!

We have reels for any conceivable application. The common applications we have identified on construction site, trucks, mixers and more include, but are not limited to:

- Pneumatic, hydraulic, and power tools
- High volume fluid delivery
- Concrete mixers and cement trucks
- Pressure washing / washdown
- Vacuum
- Lubrication
- Paving / sealcoating
- Fueling & DEF
- Welding (Arc / Gas)

Our versatile and wide reel selection handles various capacities and comes in different sizes to suit any construction requirement. Our standard reeling devices suggested in this catalog are already specified to meet the needs of the construction markets. Coxreels also has the engineering power to design and build custom reels, so please consult the factory if you cannot locate a reel that will work with your equipment, we will be happy to assist you with a solution.

VALUE THE DIFFERENCE...

Make COXREELS your reel choice!



PROFESSIONAL GRADE FEATURES

A HIGHER LEVEL OF STANDARDS



CPC™ POWDER COAT
Our blue powder coat finish is long lasting, chip resistant & rust inhibiting



BRASS SWIVEL
External fluid path, machined from solid brass, full flow, swivel for simple seal maintenance



STEEL AXLE
1" solid steel axle & lubricated bearings for extra strength & durability. Not a hollow tube & no fluid travels through it



STEEL CONSTRUCTION
High-Quality steel construction provides superior strength and durability for heavy-duty applications in commercial and industrial settings



COMPONENT COVER
External CPC powder coated steel components cover for simple slip ring routine maintenance



EZ-COIL® SERIES
A patented safety system that retracts up to 80% slower than conventional reels



CNC SPUN DISCS
All steel rolled edges & ribbed discs for added safety, strength & durability

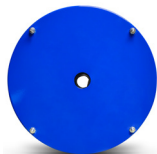

CARTRIDGE MOTOR
Enclosed factory tuned & matched cartridge style motor for safe & easy replacement

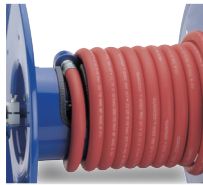

LOW PROFILE RISER
Low profile riser with open drum slot allows for smooth even hose wraps that will not pinch or bind your hose. **NO HUMP!**

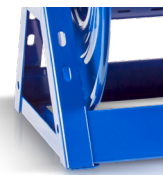

ALL WELDED STEEL "A" FRAME
All welded steel "A" frame for strength & durability. **NOT BOLTED!**



2 YEAR WARRANTY
Coxreels proudly stands behind our reels as they are built to last!



USA MADE, QUALITY & SUPPORT
We take great pride in designing, building & supplying the world's finest reels made right here in the U.S.A.

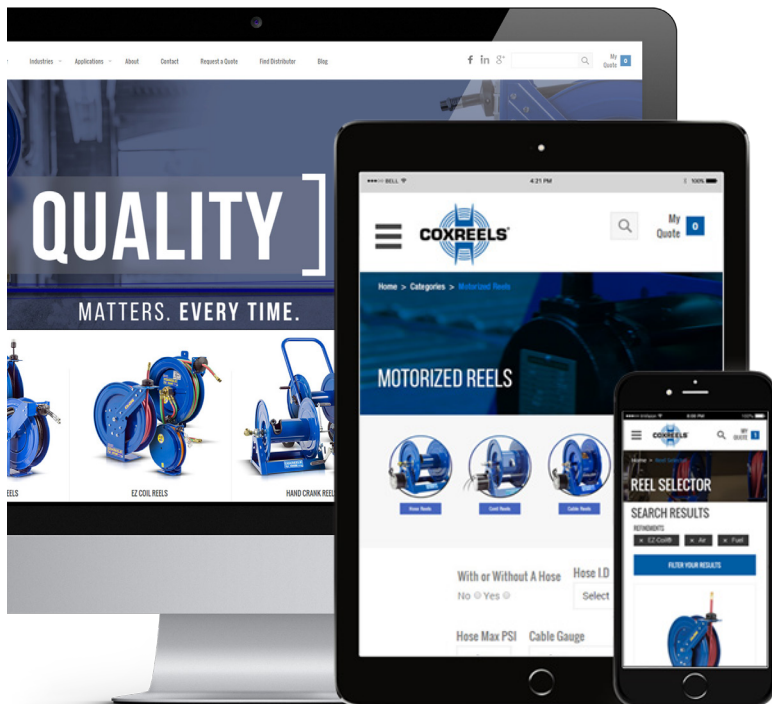

VISIT US ONLINE

Coxreels is committed to providing our customers with the ultimate online experience as they navigate through the most complete and diverse line of hose, cord, and cable reels.

We hope that you enjoy the fresh look and feel of our updated website and find that this portal serves as a valuable resource for you!

FOLLOW US



www.coxreels.com • 1.800.COX.REEL

CONSTRUCTION 3

1/4" - 1/2" I.D.

P SERIES

PERFORMANCE HOSE REELS



COXREELS® P Series "Performance" spring driven hose reels have a long history of dependability and trouble free performance. Their compact space-saving size and heavy duty construction make them highly versatile and virtually indestructible. Time-tested proven components, superior design and craftsmanship have contributed to it's worldwide reputation as the most trusted hose reel.

P SERIES

Do not exceed listed hose O.D. to obtain maximum length.

HOSE							LESS HOSE		SIZE INDEX	
MODEL	I.D.	O.D.	FT.	PSI	APRX. LBS.	EZ-COIL MODELS	MODEL	APRX. LBS.		
LOW PRESSURE							Models with hose are for air water service with a maximum temperature 150°F. Models less hose can be used for air, water or oil.			
P-LP-125	1/4"	1/2"	25	300	27	EZ-P-LP-125	P-LPL-125	24	1	
P-LP-150	1/4"	1/2"	50	300	40	EZ-P-LP-150	P-LPL-150	35	3	
P-LP-325	3/8"	5/8"	25	300	28	EZ-P-LP-325	P-LPL-325	25	2	
P-LP-350	3/8"	5/8"	50	300	43	EZ-P-LP-350	P-LPL-350	36	3	
P-LP-425	1/2"	3/4"	25	300	44	-	P-LPL-425	39	4	
P-LP-450	1/2"	3/4"	50	300	48	EZ-P-LP-450	P-LPL-450	43	4	
MEDIUM PRESSURE							Reels are furnished with standard one wire braid hose suitable for air, water or oil applications. Hose exceeds SAE R1 specifications. Maximum Temperature 212°F (if used with water, synthetic fluids 135°F max.)			
P-MP-325	3/8"	1 1/16"	25	3,000	49	-	P-MPL-325	42	4	
P-MP-425	1/2"	1 3/16"	25	2,500	49	EZ-P-MP-425	P-MPL-425	42	4	
HIGH PRESSURE							Reels are furnished standard with S.A.E. 100R16 #1 or #2 wire braid hose suitable for grease and hydraulic oil applications. Maximum Temperature 212°F. (if used with water, synthetic fluids 135°F max.)			
P-HP-125	1/4"	9/16"	25	5,000	48	EZ-P-HP-125	P-HPL-125	42	4	
P-HP-325	3/8"	1 1/16"	25	4,000	49	EZ-P-HP-325	P-HPL-325	42	4	

To order EZ-Coil® equipped models less hose, please add prefix "EZ-"

P SERIES :: REEL SPECIFICATIONS

SWIVEL

- External fluid path with machined from solid brass 90° full-flow NPT swivel inlet (Zinc plated steel swivel on HP models)
- Swivel Seals: NITRILE

DESIGN & STRUCTURE

- Sturdy single pedestal reel with space saving design facilitates workplace organization
- Guide arm adjusts to wall, floor, vehicle & overhead positions
- Solid one piece, heavy gauge 1/4" steel base & support post for maximum stability
- 1" solid steel axle & lubricated precision bearings for smooth rotation
- Controlled retraction speed up to 80% slower on **EZ-COIL** models
- Enclosed factory tuned & matched cartridge-style spring motor
- Non-corrosive stainless steel spring, pawl & zinc plated ratchet
- Multi-position lock ratchet mechanism secures hose at desired length

WARNING: Cancer and reproductive Harm – For more information – www.P65Warning.ca.gov

TOP REQUESTED UPGRADES & ACCESSORIES

SEE PAGE 21 FOR ADDITIONAL ACCESSORIES

REEL DIMENSIONS

SIZE INDEX	W	H	L	X	Y	M	N
1	5 7/8"	14 7/8"	13 1/2"	5"	6"	3"	5"
2	6 1/2"	14 7/8"	13 1/2"	5"	6"	3"	5"
3	6 3/4"	18 5/8"	17 1/8"	6"	6"	4"	5"
4	7"	18 5/8"	17 1/8"	6"	6"	4"	5"

Overall Dimensions Base Mounting Pattern

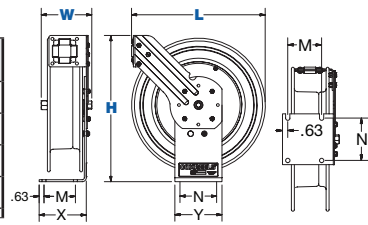

ORDER EZ-COIL® MODELS

EZ-Coil® is a patented controlled retraction technology offered exclusively on Coxreels' Safety Series reels. It retracts up to 80% slower than conventional reels, resulting in workplace safety, protection from injury & costly property damage.

UPGRADE TO NITRILE OR RUBBER HOSE

NITRILE HOSE: Premium high quality, oil resistant, multi-purpose hose. The high tensile spiral synthetic yarn reinforcement provides excellent kink resistance. Temperature range: -20° F to +212° F.

SYNTHETIC RUBBER HOSE: Versatile general purpose hose. The synthetic rubber tube and cover resists heat, sunlight, ozone, and weathering. Temperature range -40° F to +212° F

UPGRADE TO STAINLESS STEEL SWIVEL

Based on the upgraded medium pressure swivel, the stainless steel swivel is machined from solid 316 stainless steel and features increased wall thicknesses with upgraded seals and backup rings.

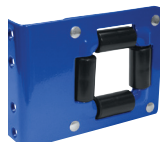

UPGRADE TO SOLID ROLLERS

Heavy duty machined from solid plastic rollers.



ADD AIR TOOL KIT

BEND RESTRICTOR: Designed to limit the degree of bending without compromising the integrity of the hose assembly while also preventing the hose-end from kinking, excessive wearing, and tearing. Available for low pressure models.

QUICK DISCONNECT: Quick disconnect couplings tread onto end of hose fitting to provide fast, leak-proof connections for low pressure hose lines.



ADD BEND RESTRICTOR

Designed to limit the degree of bending without compromising the integrity of the hose assembly while also preventing the hose-end from kinking, excessive wearing, and tearing. Available for low pressure models



COXREELS® SH Series "Super Hub™" spring driven hose reels, like the P Series, have a long history of dependable performance. The larger chassis and frame accommodate longer lengths and larger diameters of hose. Coxreels' original Super Hub™ dual axle support system increases the stability during operation, reduces vibration and strengthens the structural integrity of the reel.

SH, MP & HP SERIES

Do not exceed listed hose O.D. to obtain maximum length.

HOSE							LESS HOSE		SIZE INDEX
MODEL	I.D.	O.D.	FT.	PSI	APRX. LBS.	EZ-COIL MODELS	MODEL	APRX. LBS.	
LOW PRESSURE Models with hose are for air water service with a maximum temperature 150°F. Models less hose can be used for air, water or oil.									
SH-N-350	3/8"	5/8"	50	300	50	EZ-SH-350	SHL-N-350	44	1
SH-N-3100	3/8"	5/8"	100	300	71	EZ-SH-3100	SHL-N-3100	60	2
SH-N-450	1/2"	3/4"	50	300	54	EZ-SH-450	SHL-N-450	46	1
SH-N-4100	1/2"	3/4"	100	300	81	EZ-SH-4100	SHL-N-4100	66	3
MEDIUM PRESSURE Reels are furnished with standard one wire braid hose suitable for air, water or oil applications. Hose exceeds SAE R1 specifications. Maximum Temperature 250°F.									
MP-N-350	3/8"	1 1/16"	50	3,000	65	EZ-MP-350	MPL-N-350	53	1
MP-N-450	1/2"	1 3/16"	50	2,500	67	EZ-MP-450	MPL-N-450	53	4
HIGH PRESSURE Reels are furnished standard with S.A.E. 100R16 #1 or #2 wire braid hose suitable for grease and hydraulic oil applications. Maximum Temperature 250°F.									
HP-N-150	1/4"	9/16"	50	5,000	64	EZ-HP-150	HPL-N-150	53	4
HP-N-350	3/8"	1 1/16"	50	4,000	65	EZ-HP-350	HPL-N-350	53	5

To order EZ-Coil® equipped models less hose, please add prefix "EZ-"

REEL DIMENSIONS

SIZE INDEX	W	H	L	X	Y	M	N
1	8 1/4"	21 1/4"	19 1/2"	6"	6"	4"	5"
2	8 1/4"	25 1/2"	24"	6"	6"	4"	5"
3	8 3/4"	25 1/2"	24"	6"	6"	4"	5"
4	8 3/4"	21 1/4"	19 1/2"	6"	6"	4"	5"
5	9 1/4"	21 1/4"	19 1/2"	6"	6"	4"	5"

Overall Dimensions Base Mounting Pattern

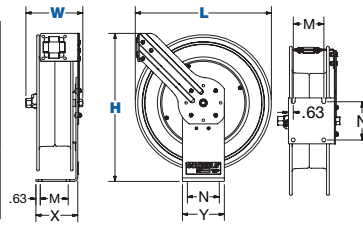

Technical Data Sheets Available On Website



Double axle support with Super Hub™

SH, MP & HP SERIES :: REEL SPECIFICATIONS

SWIVEL

- External fluid path with machined from solid brass 90° full-flow NPT swivel inlet (Zinc plated steel swivel on HP models)
- Swivel Seals: NITRILE

DESIGN & STRUCTURE

- Sturdy single pedestal reel features Coxreels' exclusive Super Hub™ dual axle support system
- Guide arm adjusts to wall, floor, vehicle & overhead positions
- Solid one piece, heavy gauge 1/4" steel base & support post for maximum stability
- 1" solid steel axle & lubricated precision bearings for smooth rotation
- Controlled retraction speed up to 80% slower on EZ-COIL models
- Enclosed factory tuned & matched cartridge-style spring motor
- Non-corrosive stainless steel spring, pawl & zinc plated ratchet
- Multi-position lock ratchet mechanism secures hose at desired length

WARNING: Cancer and reproductive Harm – For more information – www.P65Warning.ca.gov

SEE PAGE 21 FOR ADDITIONAL ACCESSORIES

TOP REQUESTED UPGRADES & ACCESSORIES



ORDER EZ-COIL® MODELS

EZ-Coil® is a patented controlled retraction technology offered exclusively on Coxreels' Safety Series reels. It retracts up to 80% slower than conventional reels, resulting in workplace safety, protection from injury & costly property damage.

UPGRADE TO NITRILE OR RUBBER HOSE

NITRILE HOSE: Premium high quality, oil resistant, multi-purpose hose. The high tensile spiral synthetic yarn reinforcement provides excellent kink resistance. Temperature range: -20° F to +212° F.

SYNTHETIC RUBBER HOSE: Versatile general purpose hose. The synthetic rubber tube and cover resists heat, sunlight, ozone, and weathering. Temperature range -40° F to +212° F

UPGRADE TO STAINLESS STEEL SWIVEL

Based on the upgraded medium pressure swivel, the stainless steel swivel is machined from solid 316 stainless steel and features increased wall thicknesses with upgraded seals and backup rings.

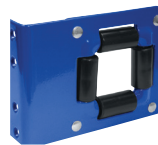

UPGRADE TO SOLID ROLLERS

Heavy duty machined from solid plastic rollers.



ADD AIR TOOL KIT

BEND RESTRICTOR: Designed to limit the degree of bending without compromising the integrity of the hose assembly while also preventing the hose-end from kinking, excessive wearing, and tearing. Available for low pressure models.

QUICK DISCONNECT: Quick disconnect couplings tread onto end of hose fitting to provide fast, leak-proof connections for low pressure hose lines.



ADD BEND RESTRICTOR

Designed to limit the degree of bending without compromising the integrity of the hose assembly while also preventing the hose-end from kinking, excessive wearing, and tearing. Available for low pressure models



1/4" - 1" I.D.

T SERIES

SUPREME DUTY HOSE REELS



Triple axle support with a full frame & Super Hub™

COXREELS® T Series "Truck Mount" spring driven hose reels are the toughest hose reels in the spring driven line. The extra large chassis with dual pedestal-style arms and Coxreels' Super Hub™ provides triple axle support while reducing vibration and strengthening the structural integrity of the reel. Making it perfect for on and off-road applications that demand reliability in the most abusive and demanding environments.

T SERIES

Do not exceed listed hose O.D. to obtain maximum length.

		HOSE					EZ-COIL MODELS			LESS HOSE		SIZE INDEX
MODEL	I.D.	O.D.	FT.	PSI	APRX. LBS.	MODEL	APRX. LBS.	MODEL	APRX. LBS.	MODEL		
LOW PRESSURE												
Models with hose are for air water service with a maximum temperature 150°F. Models less hose can be used for air, water or oil.												
TSH-N-350	3/8"	5/8"	50	300	61	EZ-TSH-350		TSHL-N-350	55		1	
TSH-N-3100	3/8"	5/8"	100	300	85	EZ-TSH-3100		TSHL-N-3100	74		2	
TSH-N-450	1/2"	3/4"	50	300	63	EZ-TSH-450		TSHL-N-450	55		1	
TSH-N-4100	1/2"	3/4"	100	300	95	EZ-TSH-4100		TSHL-N-4100	80		2	
TSH-N-550	3/4"	1 1/16"	50	300	83	EZ-TSH-550		TSHL-N-550	70		3	
TSH-N-650	1"	1 1/2"	50	300	98	-		TSHL-N-650	77		4	
MEDIUM PRESSURE												
Reels are furnished with standard one wire braid hose suitable for air, water or oil applications. Hose exceeds SAE R1 specifications. Maximum Temperature 250°F.												
TMP-N-350	3/8"	1 1/16"	50	3,000	74	EZ-TMP-350		TMPL-N-350	61		1	
TMP-N-375	3/8"	1 1/16"	75	3,000	99	EZ-TMP-375		TMPL-N-375	80		2	
TMP-N-3100	3/8"	1 1/16"	100	3,000	106	-		TMPL-N-3100	82		2	
TMP-N-450	1/2"	1 3/16"	50	2,500	77	EZ-TMP-450		TMPL-N-450	64		1	
TMP-N-475	1/2"	1 3/16"	75	2,500	100	EZ-TMP-475		TMPL-N-475	80		2	
TMP-N-4100	1/2"	1 3/16"	100	2,500	106	-		TMPL-N-4100	80		2	
TMP-N-550	3/4"	1 1/16"	50	1,500	94	EZ-TMP-550		TMPL-N-550	74		3	
TMP-N-575	3/4"	1 1/16"	75	1,500	100	-		TMPL-N-575	77		5	
TMP-N-650	1"	1 3/8"	50	1,250	116	-		TMPL-N-650	81		5	
HIGH PRESSURE												
Reels are furnished standard with S.A.E. 100R16 #1 or #2 wire braid hose suitable for grease and hydraulic oil applications. Maximum Temperature 250°F.												
THP-N-150	1/4"	9/16"	50	5,000	74	EZ-THP-150		THPL-N-150	62		1	
THP-N-175	1/4"	9/16"	75	5,000	88	EZ-THP-175		THPL-N-175	71		2	
THP-N-375	3/8"	1 1/16"	75	4,000	98	EZ-THP-375		THPL-N-375	80		2	

To order EZ-Coil® equipped models less hose, please add prefix "EZ-"

REEL DIMENSIONS

SIZE INDEX	W	H	L	X	Y	M	N
1	9 3/8"	21 1/4"	19 1/2"	8"	9"	7"	8"
2	9 3/8"	25 1/2"	24"	8"	9"	7"	8"
3	9 7/8"	25 1/2"	24"	8"	9"	7"	8"
4	12"	25 1/2"	24"	8"	9"	7"	8"
5	12 1/2"	25 1/2"	24"	8"	9"	7"	8"

Overall Dimensions Base Mounting Pattern

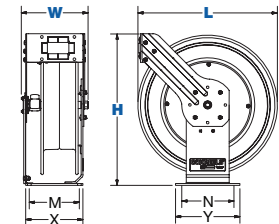

Technical Data Sheets Available On Website

SEE PAGE 21 FOR ADDITIONAL ACCESSORIES

T SERIES :: REEL SPECIFICATIONS

SWIVEL

- External fluid path with machined from solid brass 90° full-flow NPT swivel inlet (Zinc plated steel swivel on HP models)
- Electroless nickel plated steel swivel on 1" models
- Swivel Seals: NITRILE

DESIGN & STRUCTURE

- Sturdy dual pedestal reel features Coxreels' exclusive Super Hub™ dual axle support system
- Built for rugged mobile applications
- Guide arm adjusts to wall, floor, vehicle & overhead positions
- Stainless Steel rollers on 3/4" & 1" models
- Solid one piece, heavy gauge 1/4" steel base & support posts for maximum strength
- 1" solid steel axle & lubricated precision bearings for smooth rotation
- Controlled retraction speed up to 80% slower on EZ-COIL models
- Enclosed factory tuned & matched cartridge-style spring motor
- Non-corrosive stainless steel spring, pawl & zinc plated ratchet
- Multi-position lock ratchet mechanism secures hose at desired length

WARNING: Cancer and reproductive Harm – For more information – www.P65Warning.ca.gov

TOP REQUESTED UPGRADES & ACCESSORIES



ORDER EZ-COIL® MODELS

EZ-Coil® is a patented controlled retraction technology offered exclusively on Coxreels' Safety Series reels. It retracts up to 80% slower than conventional reels, resulting in workplace safety, protection from injury & costly property damage.

UPGRADE TO NITRILE OR RUBBER HOSE

NITRILE HOSE: Premium high quality, oil resistant, multi-purpose hose. The high tensile spiral synthetic yarn reinforcement provides excellent kink resistance. Temperature range: -20° F to +212° F.

SYNTHETIC RUBBER HOSE: Versatile general purpose hose. The synthetic rubber tube and cover resists heat, sunlight, ozone, and weathering. Temperature range -40° F to +212° F

UPGRADE TO STAINLESS STEEL SWIVEL

Based on the upgraded medium pressure swivel, the stainless steel swivel is machined from solid 316 stainless steel and features increased wall thicknesses with upgraded seals and backup rings.



UPGRADE TO SOLID ROLLERS

Heavy duty machined from solid plastic rollers. Only for T Series models 3/8" and 1/2".

ADD AIR TOOL KIT

BEND RESTRICTOR: Designed to limit the degree of bending without compromising the integrity of the hose assembly while also preventing the hose-end from kinking, excessive wearing, and tearing. Available for low pressure models.

QUICK DISCONNECT: Quick disconnect couplings tread onto end of hose fitting to provide fast, leak-proof connections for low pressure hose lines.

ADD BEND RESTRICTOR

Designed to limit the degree of bending without compromising the integrity of the hose assembly while also preventing the hose-end from kinking, excessive wearing, and tearing. Available for low pressure models



EXTREME DUTY SERIES

3/8" - 1" I.D.

COXREELS® XTM "Extreme Duty" Series is designed for high demand industries requiring a level of construction above truck duty. Built with mining, off-road, heavy equipment, and heavy equipment lubrication in mind, the XTM series features the most robust offerings of the reel industry. This series is the combination of all the heavy duty features available inside a solid all-welded box frame, with an integral roller bracket, focused to deliver the toughest reel for the toughest environments and applications.

XTM SERIES

HOSE						LESS HOSE		SIZE INDEX
MODEL	I.D.	O.D.	FT.	PSI	APRX. LBS.	MODEL	APRX. LBS.	
LOW PRESSURE						Models with hose are for air water service with a maximum temperature 150°F. Models less hose can be used for air, water or oil.		
XTM-LP-375	3/8"	5/8"	75	300	89	-	-	1
XTM-LP-3100	3/8"	5/8"	100	300	92	-	-	1
XTM-LP-475	1/2"	3/4"	75	300	92	-	-	1
XTM-LP-4100	1/2"	3/4"	100	300	96	-	-	1
XTM-LP-550	3/4"	1 1/16"	35	300	94	-	-	1
XTM-LP-575	3/4"	1 1/16"	50	300	101	-	-	2
XTM-LP-650	1"	1 1/2"	50	300	114	XTM-LPL-650	83	2
MEDIUM PRESSURE						Reels are furnished with standard one wire braid hose suitable for air, water or oil applications. Hose exceeds SAE R1 specifications. Maximum Temperature 250°F.		
XTM-MP-350	3/8"	1 1/16"	50	3,000	91	-	-	1
XTM-MP-375	3/8"	1 1/16"	75	3,000	95	-	-	1
XTM-MP-3100	3/8"	1 1/16"	100	3,000	99	XTM-MPL-3100	81	1
XTM-MP-450	1/2"	1 3/16"	50	2,500	93	-	-	1
XTM-MP-475	1/2"	1 3/16"	75	2,500	98	-	-	1
XTM-MP-4100	1/2"	1 3/16"	100	2,500	104	XTM-MPL-4100	81	1
XTM-MP-550	3/4"	1 1/16"	50	1,500	97	XTM-MPL-550	81	1
XTM-MP-575	3/4"	1 1/16"	75	1,500	108	XTM-MPL-575	83	2
XTM-MP-650	1"	1 3/8"	50	1,250	110	XTM-MPL-650	83	2
HIGH PRESSURE						Reels are furnished standard with S.A.E. 100R16 #1 or #2 wire braid hose suitable for grease and hydraulic oil applications. Maximum Temperature 250°F.		
XTM-HP-350	3/8"	1 1/16"	50	4,000	96	-	-	1
XTM-HP-375	3/8"	1 1/16"	75	4,000	103	XTM-HPL-375	81	1



Bottom Mount

EXTREME DUTY SERIES :: REEL SPECIFICATIONS

- SWIVEL**
 - External fluid path with machined from solid brass 90° full-flow NPT swivel inlet & swivel retaining plates (Zinc plated steel swivel on HP models)
 - Electroless nickel plated steel swivel on 1" models
 - Swivel Seals: NITRILE
- DESIGN & STRUCTURE**
 - Fully welded box frame construction, with redundant flanges. Wider frames feature Coxreels' exclusive Super Hub™ triple axle support system
 - Accessible stainless steel pawl and pawl spring on ratchet locking mechanism
 - Stainless Steel rollers on all models
 - 1" solid steel axle & dual lubricated precision bearings for smooth & stable rotation
 - Enclosed factory tuned & matched cartridge-style spring motor
 - Non-corrosive stainless steel spring, pawl & zinc plated ratchet
 - Multi-position lock ratchet mechanism secures hose at desired length

SPRING DRIVEN

EZ-COIL®

REEL DIMENSIONS

SIZE INDEX	W	H	L	X	Y	M	N
1	10 1/8"	26 1/8"	24 1/16"	10"	15"	8 29/32"	10"
2	12 3/4"	26 1/8"	24 1/16"	12 3/4"	15"	11 11/16"	10"
FLOOR MOUNT							
1	10 11/16"	26 15/16"	24 5/8"	10"	15"	8 29/32"	10"
2	13 7/16"	26 15/16"	24 5/8"	12 3/4"	15"	11 11/16"	10"
WALL MOUNT							
1	10 11/16"	26 25/32"	24 13/16"	10"	15"	8 29/32"	10"
2	13 7/16"	26 25/32"	24 13/16"	12 3/4"	15"	11 11/16"	10"

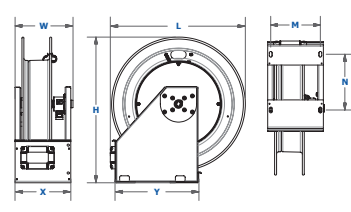

Technical Data Sheets Available On Website

TOP REQUESTED UPGRADES & ACCESSORIES

SEE PAGE 13 FOR ADDITIONAL ACCESSORIES



UPGRADE TO NITRILE OR RUBBER HOSE

NITRILE HOSE: Premium high quality, oil resistant, multi-purpose hose. The high tensile spiral synthetic yarn reinforcement provides excellent kink resistance. Temperature range: -20° F to +212° F.

SYNTHETIC RUBBER HOSE: Versatile general purpose hose. The synthetic rubber tube and cover resists heat, sunlight, ozone, and weathering. Temperature range -40° F to +212° F.



UPGRADE TO STAINLESS STEEL SWIVEL

Based on the upgraded medium pressure swivel, the stainless steel swivel is machined from solid 316 stainless steel and features increased wall thicknesses with upgraded seals and backup rings.



ADDITIONAL MOUNTING POSITIONS

XTM Reel comes in standard position - Bottom Mount. Available in floor mount and wall mount.

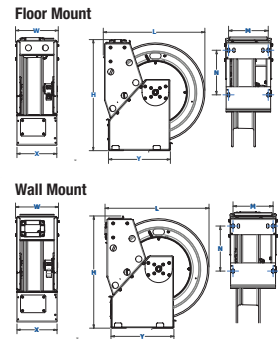

1/2" - 1 1/2" I.D.

SP SERIES

HIGH CAPACITY HOSE REELS



COXREELS® SP Series "Single Product Delivery" spring driven hose reels are built to handle large hose diameters. Used in applications demanding large volume delivery in low and medium pressures such as fuel and water. The sturdy box-style frame has heavy duty steel cross supports to all four corners for extra strength and rigidity.

SP SERIES :: REEL SPECIFICATIONS

SWIVEL

- Machined from solid brass 90° full-flow NPT swivel inlets
- Electroless nickel plated steel 90° swivel on 1" models
- External fluid path with in-line electroless nickel plated steel full-flow NPT swivel on 1/4" and 1/2" models
- Swivel Seals: NITRILE (AFLAS on 1" models)
- **On Fuel Models:** Machined from solid brass 90° full-flow NPT swivel inlet for fuel dispensing applications. Electroless nickel plated steel swivel on 1" models. Swivel seals: Nitrile

DESIGN & STRUCTURE

- Reel features a sturdy box-style frame design
- Reel adjusts to wall, floor, vehicle & overhead positions
- Heavy gauge 1/4" steel base for maximum strength
- Reinforced steel frame provides maximum strength & stability
- Long lasting self-lubricated flange bearings for smooth rotation
- Heavy duty 1" stainless steel pinch-proof rollers
- Enclosed factory tuned & matched cartridge-style spring motor
- Non corrosive stainless steel pawl spring
- Cast iron lock ring with non-sparking bronze pawl
- Multi-position lock ratchet mechanism secures hose at desired length
- **On Fuel Models:** Fuel dispensing hose designed to convey non-aromatic fuels including diesel, kerosene, fuel oil & heating oil. Temperature Range: -20°F to +190°F. Provided with non-sparking mechanism

! WARNING: Cancer and reproductive Harm –
For more information – www.P65Warning.ca.gov

TOP REQUESTED UPGRADES & ACCESSORIES

SEE PAGE 21 FOR ADDITIONAL ACCESSORIES



UPGRADE TO NITRILE OR RUBBER HOSE

NITRILE HOSE: Premium high quality, oil resistant, multi-purpose hose. The high tensile spiral synthetic yarn reinforcement provides excellent kink resistance. Temperature range: -20° F to +212° F.

SYNTHETIC RUBBER HOSE: Versatile general purpose hose. The synthetic rubber tube and cover resists heat, sunlight, ozone, and weathering. Temperature range -40° F to +212° F

UPGRADE TO STAINLESS STEEL SWIVEL

STAINLESS STEEL CAPTIVE BEARING SWIVEL / STAINLESS STEEL IN-LINE SWIVEL: the stainless steel swivel is machined from solid 304 stainless steel for increased corrosion resistance. These optional stainless steel swivel are available for 1/4" and 1/2" models.

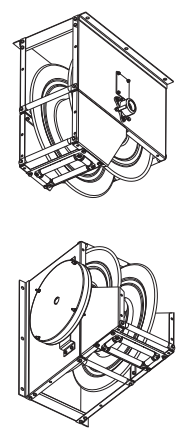

ADDITIONAL MOUNTING PATTERNS

"BXIX": Ceiling Mount. Use for stretch, recover, or lift.

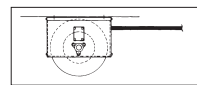

STRETCH
With Or Without Roller Guide
Special Spring Motor Required,
Consult Factory

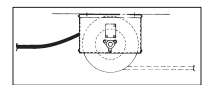

RECOVER
(Pick-up) No Roller Guide Needed,
Special Spring Motor Required,
Consult Factory

"BXCX": Wall Mount.
Use for lift.

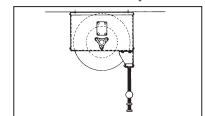

LIFT
With Roller Guide

SP SERIES

Do not exceed listed hose O.D. to obtain maximum length.

HOSE							LESS HOSE		SIZE INDEX
MODEL	I.D.	O.D.	FT.	PSI	INLET/OUTLET N.P.T.	APRX. LBS.	MODEL	APRX. LBS.	
LOW PRESSURE Dual braid hose for applications 250 to 300 psi and temperatures to 150° F. Reel less hose 250° F. For higher temperatures and pressures, see price sheet or consult factory.									
SLP-4100	1/2"	3/4"	100	300	1/2"	111	SLPL-4100	96	1
SLP-550	3/4"	1 1/16"	50	300	3/4"	99	SLPL-550	86	2
SLP-575	3/4"	1 1/16"	75	300	3/4"	136	SLPL-575	117	3
SLP-5100	3/4"	1 1/16"	100	300	3/4"	151	SLPL-5100	126	3
SLP-625	1"	1 1/2"	25	300	1"	106	SLPL-625	90	4
SLP-650	1"	1 1/2"	50	300	1"	139	SLPL-650	109	5
SLP-675	1"	1 1/2"	75	300	1"	193	SLPL-675	148	6
Please consult factory for reels with hose	1 1/4"	1 3/16"	25	250	1 1/2"***	-	SLPL-725	110	7
	1 1/4"	1 3/16"	50	250	1 1/2"***	-	SLPL-750	123	8
	1 1/2"	2 1/16"	25	250	1 1/2"	-	SLPL-825	107	7
	1 1/2"	2 1/16"	35	250	1 1/2"	-	SLPL-835	128	8
	1 1/2"	2 1/16"	50	250	1 1/2"	-	SLPL-850	138	9
MEDIUM PRESSURE Steel reinforced 100 RI hose for applications 1500 to 2500 psi and temperatures to 250° F. For higher temperatures and pressures, see price sheet or consult factory.									
SMP-4100	1/2"	1 3/16"	100	2,500	1/2"	139	SMPL-4100	113	1
SMP-550	3/4"	1 1/16"	50	1,500	3/4"	109	SMPL-550	89	2
SMP-575	3/4"	1 1/16"	75	1,500	3/4"	151	SMPL-575	121	3
SMP-5100	3/4"	1 1/16"	100	1,500	3/4"	165	SMPL-5100	126	3
Please consult factory for reels with hose	1"	1 3/8"	25	2,000	1"	-	SMPL-625	92	4
	1"	1 3/8"	50	2,000	1"	-	SMPL-650	110	5
	1"	1 3/8"	75	2,000	1"	-	SMPL-675	135	6
FUEL HOSE REELS Steel reinforced 100 RI hose for applications 1500 to 2500 psi and temperatures to 250° F. For higher temperatures and pressures, see price sheet or consult factory.									
SLPF-550	3/4"	1 1/16"	50	300	99	3/4"	SLPL-550	86	2
SLPF-575	3/4"	1 1/16"	75	300	136	3/4"	SLPL-575	117	3
SLPF-5100	3/4"	1 1/16"	100	300	151	3/4"	SLPL-5100	126	3
SLPF-625	1"	1 1/2"	25	300	106	1"	SLPL-625	90	4
SLPF-650	1"	1 1/2"	50	300	139	1"	SLPL-650	109	5
SLPF-675	1"	1 1/2"	75	300	193	1"	SLPL-675	148	6



COXREELS® PC Series spring driven "Power Cord" reels are heavy duty, industrial grade power sources. They replace tangled extension cords and self-retract to increase safety, productivity and efficiency. Modeled after the P and SH Series, the PC Series are designed for long-lasting, trouble-free performance even under the most demanding conditions.

PC SERIES

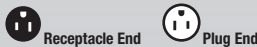

		CORD								SIZE INDEX
MODEL	ACCESSORY	INLET OUTLET	AWG / NO COND.	CORD FT.	TYPE	VOLTS	AMPS	APRX. LBS.	EZ-COIL MODELS	
FOR INDOOR USE ONLY! All models rated at 115 volts, 60 hz single phase only.										
PC13-3516-A†	Single Industrial Receptacle†	⊕	16 / 3	35	SJO	115	13	34	-	1
PC13-5016-A†			16 / 3	50	SJO	115	13	36	EZ-PC13-5016-A	1
PC24-0016-A†			16 / 3	100	SJO	115	13	73	EZ-PC24-0016-A	4
PC13-3512-A†	Single Industrial Receptacle†	⊖	12 / 3	35	SJO	115	20	37	-	1
PC13-5012-A†			12 / 3	50	SJO	115	20	40	EZ-PC13-5012-A	1
PC24-0012-A†			12 / 3	100	SJO	115	20	81	EZ-PC24-0012-A	4
PC13-3512-B†	Quad "4 Plug" Industrial Receptacle†	⊕⊖	12 / 3	35	SJO	115	20	38	-	1
PC13-5012-B†			12 / 3	50	SJO	115	20	41	EZ-PC13-5012-B	1
PC24-0012-B†			12 / 3	100	SJO	115	20	84	EZ-PC24-0012-B	4
PC13-3516-F†	Duplex G.F.C.I. Metal Industrial Receptacle†	⊕	16 / 3	35	SJO	115	13	36	-	1
PC13-5016-F†			16 / 3	50	SJO	115	13	38	EZ-PC13-5016-F	1
PC24-0016-F†			16 / 3	100	SJO	115	13	73	EZ-PC24-0016-F	4
PC13-3512-F†		⊖	12 / 3	35	SJO	115	20	39	-	1
PC13-5012-F†			12 / 3	50	SJO	115	20	42	EZ-PC13-5012-F	1
PC24-0012-F†			12 / 3	100	SJO	115	20	83	EZ-PC24-0012-F	4
PC24-0016-X	With Cord, Less Accessory	⊕	16 / 3	100**	SJO	115	13	71	EZ-PC24-0016-X	4
PC13-5012-X††			12 / 3	50**	SJO	115	20	40	EZ-PC13-5012-X	1
PC24-0012-X			12 / 3	100**	SJO	115	20	81	EZ-PC24-0012-X	4
PC13-3516-4	With Cord, Less Accessory	⊕⊖	16 / 4	35	SJO	115	10	34	-	1
PC13-5016-4			16 / 4	50	SJO	115	10	36	-	1
PC24-0016-4			16 / 4	100	SJO	115	10	74	-	4
PC13-3512-4			12 / 4	35	SJO	115	20	31	-	1
PC13-5012-4			12 / 4	50	SJO	115	20	40	EZ-PC13-5012-4	1
PC24-0012-4			12 / 4	100	SJO	115	20	85	-	4



UL Listed †

UL Listed ††

PC SERIES :: REEL SPECIFICATIONS

SLIP RING

- External heavy gauge CPC™ powder coated steel components cover for simple slip ring routine maintenance
- Electrical current runs through a 25AMP / 600V rated slip ring (35AMP on select models)
- Include 5' lead cable & grounding plug (except on less cord models)

DESIGN & STRUCTURE

- Single pedestal cord reel with space saving design facilitates workplace organization
- Guide arm adjusts to wall, floor & overhead positions
- Solid one piece, heavy gauge 1/4" steel base & support post for maximum stability
- Coxreels' exclusive Super Hub™ dual axle support system on models with size index #4
- 1" solid steel axle & lubricated precision bearings for smooth rotation
- Controlled retraction speed up to 80% slower on EZ-COIL models
- Enclosed factory tuned & matched cartridge-style spring motor
- Non-corrosive stainless steel spring, pawl & zinc plated ratchet
- Multi-position lock ratchet mechanism secures cord at desired length

SPRING DRIVEN

EZ-COIL®

REEL DIMENSIONS

SIZE INDEX	W	H	L	X	Y	M	N
1	8 1/2"	14 7/8"	13 1/2"	5"	6"	3"	5"
2	10 1/4"	25 1/2"	24"	6"	6"	4"	5"

Overall Dimensions Base Mounting Pattern

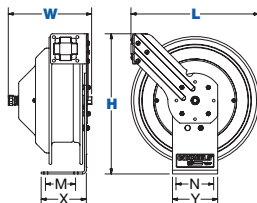

Technical Data Sheets Available On Website

WARNING: Cancer and reproductive Harm – For more information – www.P65Warning.ca.gov

SEE PAGE 21 FOR ADDITIONAL ACCESSORIES

TOP REQUESTED UPGRADES & ACCESSORIES



ORDER EZ-COIL® MODELS

EZ-Coil® is a patented controlled retraction technology offered exclusively on Coxreels' Safety Series reels. It retracts up to 80% slower than conventional reels, resulting in workplace safety, protection from injury & costly property damage.



UPGRADE TO SOLID ROLLERS

Heavy duty machined from solid plastic rollers.



ORDER LIGHT MODELS

- E SUFFIX: Caged drop light with tool tap plug.
- H SUFFIX: Industrial duty LED light 6X 3W HO
- K SUFFIX: Industrial duty LED light 12X 1W SMD
- M SUFFIX: Industrial duty LED light 8W COB



1/4" I.D.

P-W & SHW SERIES

SPRING DRIVEN WELDING HOSE REELS



COXREELS® P-W and SHW Series spring driven "Welding" hose reels are the ideal solution for managing bulky twin line welding hose. The P-W Series, like the P Series, is more compact in size and shares the reputation for long lasting performance. The SHW Series has a larger chassis and frame to accommodate longer lengths of welding hose and Coxreels' original Super Hub dual axle support system for increased stability during operation, less vibration and greater structural integrity.

P-W & SHW SERIES

Do not exceed listed hose O.D. to obtain maximum length.

HOSE						LESS HOSE		
MODEL	I.D.	FT.	PSI	APRX. LBS.	EZ-COIL MODELS	MODEL	APRX. LBS.	SIZE INDEX
OXYGEN-ACETYLENE						Hose supplied on reel is twin-siamese type meeting R.M.A. and C.G.A. type V.D. grade R specifications. Use of other types of hose is not recommended.		
P-W-125	1/4"	25	200	46	EZ-P-W-125	P-WL-125†	39	1
SHW-N-150	1/4"	50	200	64	EZ-SHW-150	SHWL-N-150†	52	2
SHW-N-1100	1/4"	100	200	84	EZ-SHW-1100	SHWL-N-1100	62	3
OTHER FUELS						Hose supplied on reel is twin-siamese type grade "T." Grade "T" reels and hoses are used for a wide variety of gases, such as MAPP, propane, natural and fuel.		
P-WT-125	1/4"	25	200	46	EZ-P-WT-125	P-WTL-125†	39	1
SHWT-N-150	1/4"	50	200	64	EZ-SHWT-150	SHWTL-N-150†	52	2
SHWT-N-1100	1/4"	100	200	84	EZ-SHWT-1100	SHWTL-N-1100	62	3

To order EZ-Coil® equipped models less hose, please add prefix "EZ-". Less hose models comes with inlet hose



P-W & SHW SERIES :: REEL SPECIFICATIONS

SWIVEL

- External fluid path with 90° full-flow dual ported brass swivel offering both connections from the same side of the reel
- Swivel lock bracket ensures maximum safety
- Swivel Seals: VITON®

DESIGN & STRUCTURE

- Designed for Oxy-Acetylene or "T" grade welding hose
- Single pedestal reel with space saving design facilitates workplace organization
- Guide arm adjusts to wall, floor & overhead positions
- Solid one piece, heavy gauge 1/4" steel base & support post for maximum stability
- 1" solid steel axle & lubricated precision bearings for smooth rotation
- Coxreels' exclusive Super Hub™ dual axle support system on models with size index #2 & #3
- Controlled retraction speed up to 80% slower on EZ-COIL models
- Enclosed factory tuned & matched cartridge-style spring motor
- Non corrosive stainless steel spring, pawl & zinc plated ratchet
- Multi-position non-sparking lock ratchet mechanism secures hose at desired length

REEL DIMENSIONS

SIZE INDEX	W	H	L	X	Y	M	N
1	8 1/2"	18 5/8"	17"	6"	6"	4"	5"
2	10 1/4"	21 1/4"	19 1/2"	6"	6"	4"	5"
3	10 1/4"	25 1/2"	24"	6"	6"	4"	5"

Overall Dimensions Base Mounting Pattern

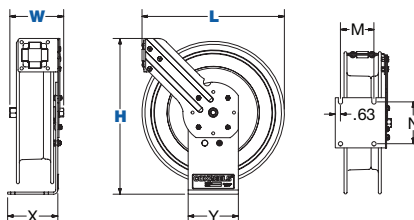

Technical Data Sheets Available On Website

TOP REQUESTED UPGRADES & ACCESSO-

SEE PAGE 21 FOR ADDITIONAL ACCESSORIES



ORDER EZ-COIL® MODELS

EZ-Coil® is a patented controlled retraction technology offered exclusively on Coxreels' Safety Series reels. It retracts up to 80% slower than conventional reels, resulting in workplace safety, protection from injury & costly property damage.



UPGRADE TO SOLID ROLLERS

Heavy duty machined from solid plastic rollers. Only for T Series models 3/8" and 1/2".



WARNING: Cancer and reproductive Harm - For more information - www.P65Warning.ca.gov



3/32" Ø

SD SERIES

STATIC DISCHARGE CABLE REELS



COXREELS® SD Series “Static Discharge” cable reels are built heavy duty and designed for long lasting performance. They are specifically designed to be used in combustible environments where the static buildup could ignite a spark and subsequent explosion. Static discharge or grounding reels are commonly paired with fuel hose reels.

SD SERIES

		CABLE			LESS CABLE		SIZE INDEX
MODEL	FT.	O.D. W/JACKET	APRX. LBS.	EZ-COIL MODELS	MODEL	APRX. LBS.	
GALVANIZED CABLE							
SD-50	50	5/32"	20	EZ-SD-50	SDL-50	18	1
SD-100	100	5/32"	32	EZ-SD-100	SDL-100	28	2
STAINLESS STEEL CABLE							
SD-50-1	50	5/32"	20	EZ-SD-50-1	SDL-50	18	1
SD-100-1	100	5/32"	32	EZ-SD-100-1	SDL-100	28	2

To order **EZ-Coil®** equipped models less cable, please add prefix "EZ-"

SD & SDH SERIES :: REEL SPECIFICATIONS

STATIC DISCHARGE

- Available with 7 strand x 7 wire galvanized steel or stainless steel 5/32" cable
- High visibility orange vinyl cable cover (O.D.= 5/32" with cable cover)
- Includes cable, ball stop & 50 Amp grounding clamp (100 Amp copper grounding clamp available, consult factory)

DESIGN & STRUCTURE

- Compact static discharge cable reel available in spring rewind or direct hand crank retraction
- Commonly paired with fuel reels & used in combustible environment for grounding purposes
- Guide arm adjusts to wall, floor, vehicle & overhead positions
- Solid one piece, heavy gauge 1/4" steel base for maximum stability
- 1" solid steel axle & lubricated precision bearings for smooth rotation
- Bottom of base is not powder coated to ground reel
- Controlled retraction speed up to 80% slower on **EZ-COIL** models
- Enclosed factory tuned & matched cartridge-style spring motor
- Non corrosive stainless steel spring, pawl & zinc plated ratchet
- Multi-position non-sparking lock ratchet mechanism secures cable at desired length

REEL DIMENSIONS

SIZE INDEX	W	H	L	X	Y	N
1	3 7/8"	11 1/2"	11"	2 1/2"	6"	4"
2	4"	15"	14 1/2"	2 1/2"	6"	4"

Overall Dimensions Base Mounting Pattern

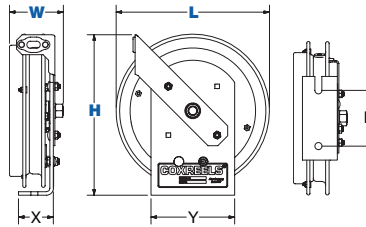

Technical Data Sheets Available On Website

SPRING DRIVEN

EZ-COIL®

! WARNING: Cancer and reproductive Harm –
For more information – www.P65Warning.ca.gov

TOP REQUESTED UPGRADES & ACCESSORIES

SEE PAGE 21 FOR ADDITIONAL ACCESSORIES



ORDER EZ-COIL® MODELS

EZ-Coil® is a patented controlled retraction technology offered exclusively on Coxreels' Safety Series reels. It retracts up to 80% slower than conventional reels, resulting in workplace safety, protection from injury & costly property damage.



ORDER DOUBLE CLAMP

Heavy duty clamps made from zinc plated steel. Both clamps are rated for 50 amp. Each has a jaw opening of 1.06" and a steel spring.



ORDER 100 AMP CLAMP

Heavy duty copper clamp designed for heavy grounding requirements. It has a jaw opening of 1.06" and a steel spring.



COXREELS® DEF Series are equipped with a stainless steel external full-flow swivel and chemical resistant Viton® seals to provide a safe, reliable Diesel Exhaust Fluid (DEF) dispensing solution. The swivel is easy to access for simple seal maintenance and fast DEF dispenser hose installation. Coxreels® professional DEF reeling systems are available in heavy-duty single pedestal (SH Series) or supreme-duty dual pedestal (T Series) configurations. Both versatile designs are outfitted with Coxreels' original Super Hub™ dual axle support systems to increase stability and reduce vibration during operation, making these reels the perfect DEF handling solutions for either stationary or rugged mobile applications.



DEF SERIES Models are equipped with DEF hose. Note: Do not exceed listed hose O.D. to obtain maximum length.

HOSE							LESS HOSE		SIZE INDEX
MODEL	I.D.	O.D.	FT.	PSI	APRX. LBS.	EZ-COIL MODELS	MODEL	APRX. LBS.	
DEF-SH SERIES									
-	1/2"	7/8"	50	300	-	-	*SHL-N-450-BBX	46	1
SH-N-525-DF-BBX	3/4"	1 1/16"	25	300	52	EZ-SH-525-DF-BBX	SHL-N-525-DF-BBX	45	2
SH-N-550-DF-BBX	3/4"	1 1/16"	50	300	69	EZ-SH-550-DF-BBX	SHL-N-550-DF-BBX	56	3
DEF-T SERIES									
-	1/2"	3/4"	50	300	-	-	*TSHL-N-450-BBX	55	4
-	3/4"	1 1/16"	35	300	-	-	*TSHL-N-535-DF-BBX	67	5
TSH-N-550-DF-BBX	3/4"	1 1/16"	50	300	83	EZ-TSH-550-DF-BBX	TSHL-N-550-DF-BBX	70	5
-	1"	1 1/2"	35	300	-	-	TSHL-N-635-BBX	71	7
-	1"	1 1/2"	50	300	-	-	TSHL-N-650-BBX	77	6

*EZ-Coil® option only available on these less hose models. Please add prefix "EZ-"

COXREELS® Fuel Dispensing Reels are designed to handle various non-aromatic fuel applications including diesel, kerosene, fuel oil and heating oil. Coxreels® professional fuel dispensing reels supreme-duty dual pedestal are an essential component found in utility, ground support, and bulk liquid handling transport services mounted on fuel storage & dispensing systems, fuel/lube trucks, aircraft refuelers, and tank trucks. The convenient uncoiling systems with the added hose control allow the operator to efficiently handle fuel transfers.

FUEL HOSE SERIES

Models are equipped with fuel hose. Note: Do not exceed listed hose O.D. to obtain maximum length.

HOSE							LESS HOSE		SIZE INDEX
MODEL	I.D.	O.D.	FT.	PSI	APRX. LBS.	EZ-COIL MODELS	MODEL	APRX. LBS.	
FUEL HOSE T SERIES									
TSHF-N-535	3/4"	1 3/16"	35	300	77	EZ-TSHF-535	TSHL-N-535-BXN	67	5
TSHF-N-550	3/4"	1 3/16"	50	300	83	EZ-TSHF-550	*TSHL-N-550-BXN	70	5
TSHF-N-575	3/4"	1 3/16"	75	300	93	-	TSHL-N-575-BXN	73	6
TSHF-N-635	1"	1 1/2"	35	300	92	-	TSHL-N-635-BXN	71	7
TSHF-N-650	1"	1 1/2"	50	300	98	-	TSHL-N-650-BXN	77	6

*EZ-Coil® option only available on these less hose models. Please add prefix "EZ-"

REEL DIMENSIONS

Technical Data Sheets Available On Website

SIZE INDEX	W	H	L	X	Y	M	N
1	8 1/4"	21 1/4"	19 1/2"	6"	6"	4"	5"
2	9 3/8"	21 1/4"	19 1/2"	6"	6"	4"	5"
3	9 7/8"	25 1/2"	24"	6"	6"	4"	5"
4	9 3/8"	21 1/4"	19 1/2"	8"	9"	7"	8"
5	9 7/8"	25 1/2"	24"	8"	9"	7"	8"
6	12"	25 1/2"	24"	8"	9"	7"	8"
7	10"	25 1/2"	24"	8"	9"	7"	8"

Overall Dimensions Base Mounting Pattern

TOP REQUESTED UPGRADES & ACCESSORIES



ORDER EZ-COIL® MODELS

EZ-Coil® is a patented controlled retraction technology offered exclusively on Coxreels' Safety Series reels. It retracts up to 80% slower than conventional reels, resulting in workplace safety, protection from injury & costly property damage.



UPGRADE TO SOLID ROLLERS

Heavy duty machined from solid plastic rollers. Only for T Series 1/2" models and SH Series.

DEF & FUEL SERIES :: REEL SPECIFICATIONS

SWIVEL

- (DEF Series) Non-corrosive stainless steel 90° full flow NPT swivel for Diesel Exhaust Fluid (DEF) dispensing applications.
- (DEF Series) Swivel seals: Viton®
- (Fueling Series) Machined from solid brass 90° full-flow NPT swivel inlet for fuel dispensing applications. Electroless nickel plated steel swivel on 1" models
- (Fueling Series) Swivel seals: Nitrile

HOSE

- DEF dispensing hose designed to convey the high-purity, aqueous urea solution DEF. Temperature Range: -40°F to +257°F
- Fuel dispensing hose designed to convey non-aromatic fuels including diesel, kerosene, fuel oil & heating oil. Temperature Range: -20°F to +190°F

DESIGN & STRUCTURE

- Guide arm adjusts to wall, floor, vehicle & overhead positions
- Solid one piece, heavy gauge 1/4" steel base & support post for maximum stability
- 1" solid steel axle & lubricated precision bearings for smooth rotation
- (On SH Series only) Sturdy single pedestal reel features Coxreels' exclusive Super Hub™ dual axle support system
- (On T Series only) Sturdy dual pedestal reel features Coxreels' exclusive Super Hub™ triple axle support system
- (On T Series only) Stainless Steel rollers
- Controlled retraction speed up to 80% slower on EZ-COIL models
- Enclosed factory tuned & matched cartridge-style spring motor
- Non-corrosive stainless steel spring, pawl & zinc plated ratchet
- Multi-position lock ratchet mechanism secures hose at desired length

WARNING: Cancer and reproductive Harm – For more information – www.P65Warning.ca.gov

SEE PAGE 21 FOR ADDITIONAL ACCESSORIES

3/8" - 3/4" I.D.

100 SERIES

COMPACT HAND CRANK HOSE REELS

COXREELS® 100 Series hand crank hose reels are **lightweight, compact, versatile reels that perform at working pressures up to 4,000 PSI.** Save time and effort while increasing the safety of your work environment. The sturdy "U" shaped frame and all steel construction make this one tough little reel. All listed models are supplied less hose.

100 SERIES - ALL REELS SUPPLIED LESS HOSE

MODEL	STANDARD CAPACITY			OPTIONAL CAPACITY Reducer Required			PSI	APRX LBS.	SIZE INDEX
	I.D.	O.D.	FT.	I.D.	O.D.	FT.			
112-3-100	3/8"	5/8"	100	1/4"	1/2"	150	4,000	19	1
112-3-150	3/8"	5/8"	150	1/4"	1/2"	225	4,000	21	2
117-3-250	3/8"	5/8"	250	1/4"	1/2"	350	4,000	30	3
117-3-400	3/8"	5/8"	400	1/4"	1/2"	550	4,000	33	4
112-4-75	1/2"	7/8"	75	3/8"	3/4"	100	4,000	21	2
117-4-225	1/2"	7/8"	225	3/8"	3/4"	315	4,000	31	4
117-4-350	1/2"	7/8"	350	3/8"	3/4"	450	4,000	37	5
117-5-100	3/4"	1 1/4"	100	1/2"	1"	150	4,000	35	6

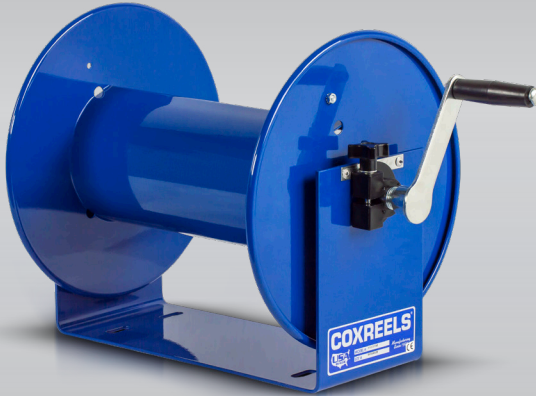

100 SERIES :: REEL SPECIFICATIONS

SWIVEL

- Machined from solid 90° full-flow NPT swivel inlet
- Up to 4,000 PSI working pressure
- Swivel Seals: NITRILE

DESIGN & STRUCTURE

- Professional grade, compact & lightweight design
- Open drum design for no hassle hose wrap
- Solid one piece, heavy gauge steel "U" shaped frame
- Adjustable tension brake to prevent "free-wheeling" during operation, transport or storage
- Direct hand crank rewind

REEL DIMENSIONS

Technical Data Sheets Available On Website

SIZE INDEX	W	H	L	X	Y	M	N	Ø	Dw
1	18 1/4"	13"	12"	9 1/2"	6"	5 1/2"	3"	5 1/2"	8"
2	22 3/4"	13"	12"	14"	6"	10"	3"	5 1/2"	12 1/2"
3	18 1/4"	18"	17"	9 1/2"	6"	5 1/2"	3"	5 1/2"	8"
4	22 3/4"	18"	17"	14"	6"	10"	3"	5 1/2"	12 1/2"
5	28 1/4"	18"	17"	19 1/2"	6"	15 1/2"	3"	5 1/2"	18"
6	23 1/4"	18"	17"	14"	6"	10"	3"	5 1/2"	12 1/2"

Overall Dimensions Base Mounting Pattern Drum

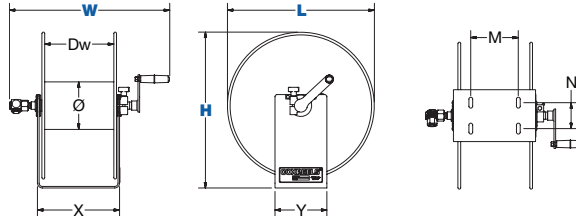

WARNING: Cancer and reproductive Harm –
For more information – www.P65Warning.ca.gov

TOP REQUESTED UPGRADES & ACCESSORIES

SEE PAGE 21 FOR ADDITIONAL ACCESSORIES



ADD ROLLERS

4-way enclosed pinch-proof stainless steel rollers are 1 in diameter supported by powder coated steel brackets. Weight: Add 10 lbs. to reel weight.



ADD PINLOCK

The spring-loaded lock pin assembly is designed to lock & secure the reel, even in mobile conditions over rough terrain.



STRENGTHEN DRUM WITH BRAWNY OPTION

The Brawny feature closes the drum opening, increasing the drum strength to resist potential damage from hose constriction under increased or pulsing pressure usage.



UPGRADE TO CAPTIVE BEARING SWIVEL

Featuring heavy duty ball bearings for smooth rotation and increased side load capabilities, our captive bearing swivel options are available in several seal configurations and material choices and can be factory installed on all of our hand crank and motorized reels lines. Also available in 304 stainless steel.



UPGRADE TO STAINLESS STEEL SWIVEL

Based on the upgraded medium pressure swivel, the stainless steel swivel is machined from solid 316 stainless steel and features increased wall thicknesses with upgraded seals and backup rings.

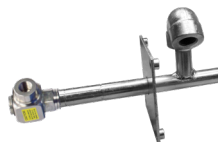

UPGRADE TO STAINLESS STEEL FLUID PATH

This options uses the same swivel as described in the stainless steel swivel upgrade and couples it to a upgraded 304 stainless steel plumbing axle to improve the corrosion resistance of the entire fluid path.



COXREELS® CM Series "Caddy Mount" and DM Series "Dolly Mount" hand crank hose reels offer lightweight, compact portability for long lengths of hose. Eliminate the task of manually coiling and uncoiling hose and easily transport it to the job site on wheels. High pressure applications are no problem with a 4,000 PSI rating. Also, a 4" inlet hose with 3/4" female fitting and male garden adaptor is available with this series for use with garden hose. See options below.

PORTABLE HOSE REELS SERIES - ALL REELS SUPPLIED LESS HOSE

MODEL	STANDARD CAPACITY			OPTIONAL CAPACITY Reducer Required			PSI	APRX LBS.	SIZE INDEX
	I.D.	O.D.	FT.	I.D.	O.D.	FT.			
CM SERIES - CADDY MOUNT									
112-3-100-CM	3/8"	5/8"	100	1/4"	1/2"	150	4,000	18	1
112-3-150-CM	3/8"	5/8"	150	1/4"	1/2"	225	4,000	22	2
117-4-225-CM	1/2"	7/8"	225	3/8"	3/4"	315	4,000	28	3
DM SERIES - DOLLY MOUNT									
117-3-200-DM	3/8"	5/8"	200	1/4"	1/2"	350	4,000	37	4
117-4-225-DM	1/2"	7/8"	225	3/8"	3/4"	315	4,000	39	5



CM & DM SERIES :: REEL SPECIFICATIONS

SWIVEL

- Machined solid brass 90° full-flow NPT swivel inlet
- Up to 4,000 PSI working pressure
- Swivel Seals: NITRILE

CM SERIES DESIGN & STRUCTURE

- High quality one piece 1" steel tube frame structure
- Hose Control bar prevents hose from slipping off the discs
- Adjustable tension brake to prevent "free-wheeling"
- Base has holes for temporary or permanent installation

DM SERIES DESIGN & STRUCTURE

- High quality three piece 1 1/4" steel tube frame structure
- Solid 8" rubber tires for easy transport
- Rubber front feet prevent reel from slipping forward
- Removable handle allow for compact storage
- Adjustable tension brake to prevent "free-wheeling"
- Direct hand crank rewind

REEL DIMENSIONS

Technical Data Sheets Available On Website

SIZE INDEX	W	H	L	X	Y	M	N	Ø	Dw
1	18 1/2"	14 3/4"	13 1/8"	11 1/2"	10 5/8"	10 1/2"	5 1/4"	5 1/2"	8"
2	23"	14 3/4"	13 1/8"	16"	10 1/2"	10 1/2"	5 1/4"	5 1/2"	12 1/2"
3	23"	18 1/2"	18"	16"	12 5/8"	10 1/2"	5 1/4"	5 1/2"	12 1/2"
4	19"	36 1/4"	21"	12"	17 1/2"	-	-	5 1/2"	8"
5	23 1/2"	36 1/4"	21"	16 1/2"	17 1/2"	-	-	5 1/2"	12 1/2"

Overall Dimensions Base Mounting Pattern Drum

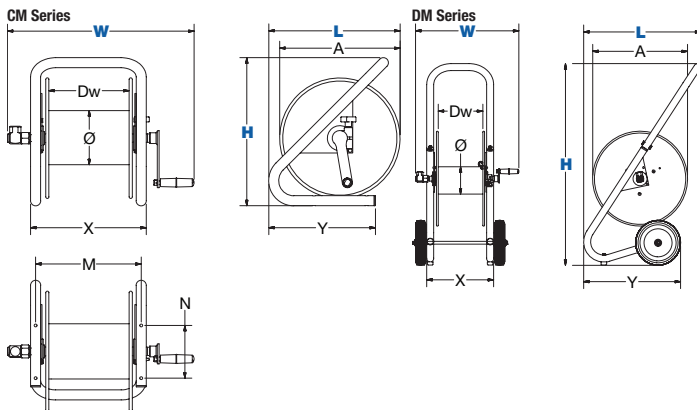

TOP REQUESTED UPGRADES & ACCESSORIES

SEE PAGE 21 FOR ADDITIONAL ACCESSORIES



GARDEN HOSE KIT

You are able to connect any hose to a reel with 1/2" plumbing. You will be able to use any garden hose for everything from watering plants to washing your car. Kit includes: NPT to garden hose adaptor & adaptor hose.



UPGRADE TO CAPTIVE BEARING SWIVEL

Featuring heavy duty ball bearings for smooth rotation and increased side load capabilities, our captive bearing swivel options are available in several seal configurations and material choices and can be factory installed on all of our hand crank and motorized reels lines. Also available in 304 stainless steel.



UPGRADE TO STAINLESS STEEL SWIVEL

Based on the upgraded medium pressure swivel, the stainless steel swivel is machined from solid 316 stainless steel and features increased wall thicknesses with upgraded seals and backup rings.

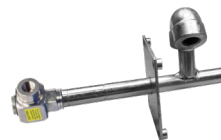

UPGRADE TO STAINLESS STEEL FLUID PATH

This options uses the same swivel as described in the stainless steel swivel upgrade and couples it to a upgraded 304 stainless steel plumbing axle to improve the corrosion resistance of the entire fluid path.

1/2" - 1" I.D.

1125 SERIES

HAND CRANK & MOTOR DRIVEN HOSE REELS



COXREELS® 1125 Series hand crank and motorized hose reels have the features demanded by industry professionals. The industry preferred design features a sturdy one piece all welded "A" frame base, low profile outlet riser and open drum slot design provides a non-crimping, flat smooth hose wrap.

1125 SERIES - ALL REELS SUPPLIED LESS HOSE

MODEL	STANDARD CAP			OPTIONAL CAP. Reducer required			INLET SWIVEL & OUTLET RISER	PSI	APPR. LBS.	SIZE INDEX
	I.D.	O.D.	FT.	I.D.	O.D.	FT.				
	1125-4-100	1/2"	7/8"	100	3/8"	3/4"				
1125-4-200	1/2"	7/8"	200	3/8"	3/4"	300	1/2" F NPT	3,000	39	2
1125-4-325	1/2"	7/8"	325	3/8"	3/4"	450	1/2" F NPT	3,000	48	3
1125-5-100	3/4"	1 1/4"	100	1/2"	7/8"	200	3/4" F NPT	3,000	42	4
1125-5-250	3/4"	1 1/4"	250	1/2"	7/8"	500	3/4" F NPT	3,000	59	5
1125-6-100	1"	1 7/16"	100	3/4"	1 1/4"	150	1" F NPT	3,000	69	6

1125 SERIES :: REEL SPECIFICATIONS

SWIVEL

- Machined solid brass 90° full-flow NPT swivel (Nickel plated steel swivel on 1" models)
- Swivel Seals: **NITRILE**
AFLAS on 1" steel models
NITRILE on 1" stainless fluid path models
- External 90° full-flow NPT swivel with electroless nickel plated steel inlet (on high pressure HP & 1" steel models)
- Swivel Seals: AFLAS (on high pressure HP prefix models)

DESIGN & STRUCTURE

- All welded steel "A" frame construction for superior reel structure
- Exclusive low profile outlet riser & open drum slot design for flat smooth hose wrap
- Permanently lubricated self-aligning pillow block bearings for trouble-free & smooth rotation
- Adjustable tension brake to prevent "free-wheeling" during operation
- Long-handled locking pin to secure reel from rotation during transport or storage
- Solid steel direct hand crank with smooth round handle
- Reliable direct gear drive on motor driven models providing quiet & smooth retraction - **NO CHAIN**

WARNING: Cancer and reproductive Harm – For more information – www.P65Warning.ca.gov

TOP REQUESTED UPGRADES & ACCESSORIES

SEE PAGE 21 FOR ADDITIONAL ACCESSORIES



5,000 PSI HIGH PRESSURE MODELS

Upgrade to 5000 PSI with a steel ball bearing swivel. Machined from high strength steel and nickel plated for corrosion resistance, the ball bearing swivel features maximum flow and enhanced load bearing capabilities. Swivel Seals: AFLAS

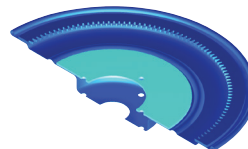

STRENGTHEN DRUM WITH BRAWNY OPTION

10 Gauge plates welded into each disc to keep them from bowing. Prevents deformations & eventual crushing of the drum that can be caused by hose pressure. The center drum has been thickened from 16GA to 14GA.



UPGRADE TO STAINLESS STEEL

STAINLESS STEEL SWIVEL / STAINLESS STEEL CAPTIVE BEARING SWIVEL: the stainless steel swivel is machined from solid 304 stainless steel for increased corrosion resistance.

STAINLESS STEEL FLUID PATH: This options uses the same swivel as described in the stainless steel swivel upgrade and couples it to a upgraded 304 stainless steel plumbing axle to improve the corrosion resistance of the entire fluid path.



ADD PINLOCK TO MOTORIZED MODELS

The spring-loaded lock pin assembly is designed to lock & secure the reel, even in mobile conditions over rough terrain.

REEL DIMENSIONS

Technical Data Sheets Available On Website

SIZE INDEX	W			H		L	X	Y		Ø	Dw
	CRANK	ELEC.	AIR / HYD.	CRANK	ELEC.			CRANK	ELEC.		
	1	19 1/2"	19 3/4"	17"	18 3/4"			19 1/4"	17 5/8"		
2	25 1/2"	25 3/4"	23"	18 3/4"	19 1/4"	17 5/8"	17 3/8"	15 3/8"	16"	6 1/4"	12"
3	31 1/2"	31 3/4"	29"	18 3/4"	19 1/4"	17 5/8"	23 3/8"	15 3/8"	16"	6 1/4"	18"
4	26 3/4"	26"	23 3/8"	18 3/4"	19 1/4"	17 5/8"	17 3/8"	15 3/8"	16"	6 1/4"	12"
5	42 3/4"	42"	39 3/8"	18 3/4"	19 1/4"	17 5/8"	33 3/8"	15 3/8"	16"	6 1/4"	28"
6	44 1/2"	42 3/8"	40 3/4"	18 1/2"	19 1/8"	17 5/8"	33 3/8"	15 3/8"	16"	8 1/4"	28"

Overall Dimensions

Base

Drum

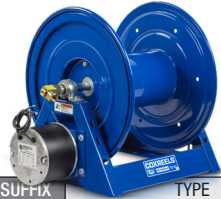

MOTORIZED THE REWIND OF YOUR REEL

Featuring a direct gear drive, the 1125 Series drive system is more dependable and maintenance free than a chain and sprocket. A solid steel ring gear is directly welded to the side of the disc for added rigidity and strength. Choose from several motor options shown in the table below.

SEE PAGE 11 FOR ADDITIONAL MOTOR ACCESSORIES

SUFFIX	TYPE	DESCRIPTION	ADD ON LBS
A	AIR - 4 VANE	ALUMINUM BODY AIR MOTOR	8
AB	AIR - 6 VANE	CAST IRON AIR MOTOR	8
C	FRONT HAND CRANK	BEVEL GEARED CRANK	3
E	12 V DC, 1/3 HP	REVERSIBLE	13
ED	12 V DC, 1/2 HP EXP.	EXPLOSION PROOF, REVERSIBLE	26
EF	24 V DC, 1/3 HP	REVERSIBLE	13
EB	24 V DC, 1/2 HP EXP.	EXPLOSION PROOF, REVERSIBLE	26
EA	115 V AC, 1/2 HP EXP.	EXPLOSION PROOF REVERSIBLE AC RECTIFIED	26
EJ	230 V AC, 1/2 HP EXP.	EXPLOSION PROOF REVERSIBLE AC RECTIFIED	26
H	HYDRAULIC	END PORTED 9/16-18 UNF	6



COXREELS® 1175 Series hand crank and motorized hose reels, like the 1125 Series, is an industry preferred design built with a larger chassis for larger hose capacities and hose diameters. They feature a sturdy one piece all welded "A" frame base, low profile outlet riser open drum slot design for smooth even hose wraps around the drum.

1175 SERIES - ALL REELS SUPPLIED LESS HOSE

MODEL	STANDARD CAP			OPTIONAL CAP. Reducer required			INLET SWIVEL ASSEMBLY	OUTLET RISER	PSI	APPRX. LBS.	SIZE INDEX
	I.D.	O.D.	FT.	I.D.	O.D.	FT.					
1175-6-50	1"	17/16"	50	3/4"	1 1/4"	100	1" F NPT 90°	1" F NPT	3,000	67	1
1175-6-100	1"	17/16"	100	3/4"	1 1/4"	150	1" F NPT 90°	1" F NPT	3,000	70	2
1175-6-150	1"	17/16"	150	3/4"	1 1/4"	250	1" F NPT 90°	1" F NPT	3,000	75	3
1175-6-200	1"	17/16"	200	3/4"	1 1/4"	300	1" F NPT 90°	1" F NPT	3,000	83	4



REEL DIMENSIONS

Technical Data Sheets Available On Website

SIZE INDEX	W			H		L	X	Y	Ø	Dw
	CRANK	ELEC.	AIR / HYD.	CRANK	ELEC.					
1	24 1/8"	22"	20 1/2"	26 1/8"	26 1/8"	24"	13"	20 1/8"	10 1/2"	7 1/2"
2	28 1/8"	26"	24 1/2"	26 1/8"	26 1/8"	24"	17"	20 1/8"	10 1/2"	11 1/2"
3	32 1/8"	30"	28 1/2"	26 1/8"	26 1/8"	24"	21"	20 1/8"	10 1/2"	15 1/2"
4	36 5/8"	34 1/2"	33"	26 1/8"	26 1/8"	24"	25 1/2"	20 1/8"	10 1/2"	20"

Overall Dimensions

Base

Drum



MOTORIZED THE REWIND OF YOUR REEL

Featuring a lubricated chain and a zinc plated steel sprocket, the 1175 Series drive system provides a smooth, continuous rewind on motorized reels. Choose from several motor options shown in the table below.

SUFFIX	TYPE	DESCRIPTION	ADD ON LBS
A	AIR - 4 VANE	ALUMINUM BODY AIR MOTOR	8
AB	AIR - 6 VANE	CAST IRON AIR MOTOR	8
C	FRONT HAND CRANK	BEVEL GEARED CRANK	3
E	12 V DC, 1/3 HP	REVERSIBLE	13
ED	12 V DC, 1/2 HP EXP.	EXPLOSION PROOF, REVERSIBLE	26
EF	24 V DC, 1/3 HP	REVERSIBLE	13
EB	24 V DC, 1/2 HP EXP.	EXPLOSION PROOF, REVERSIBLE	26
EA	115 V AC, 1/2 HP EXP.	EXPLOSION PROOF REVERSIBLE AC RECTIFIED	26
EJ	230 V AC, 1/2 HP EXP.	EXPLOSION PROOF REVERSIBLE AC RECTIFIED	26
H	HYDRAULIC	END PORTED 9/16-18 UNF	6

1175 SERIES :: REEL SPECIFICATIONS

SWIVEL

- Nickel plated steel 90° full-flow NPT swivel inlet
- Swivel Seals: AFLAS NITRILE on stainless steel fluid path
- Available with stainless steel 304 fluid path

DESIGN & STRUCTURE

- All welded steel "A" frame construction for superior reel structure
- Exclusive low profile outlet riser & open drum slot design for flat smooth hose wrap
- Permanently lubricated self-aligning pillow block bearings for trouble-free & smooth rotation
- Adjustable tension brake to prevent "free-wheeling" during operation
- Long-handled locking pin to secure reel from rotation during transport or storage
- Solid steel direct hand crank with smooth round handle
- Reliable chain & sprocket drive on motor driven models

WARNING: Cancer and reproductive Harm – For more information – www.P65Warning.ca.gov

SEE PAGE 21 FOR ADDITIONAL ACCESSORIES

TOP REQUESTED UPGRADES & ACCESSORIES



ADD 4-WAY ROLLERS

4-way enclosed pinch-proof stainless steel rollers are 1 in diameter supported by powder coated steel brackets. Weight: Add 10 lbs. to reel weight.



ADD 3-WAY ROLLERS

3-way open spool roller assembly with 1.5 chrome-plated machined steel spools & 1.5 stainless steel tubing bottom roller & powder coated steel brackets. Weight: Add 14 lbs. to reel weight.



UPGRADE TO STAINLESS STEEL

STAINLESS STEEL CAPTIVE BEARING SWIVEL: Featuring heavy duty ball bearings for smooth rotation and increased side load capabilities, the stainless steel swivel is machined from solid 304 stainless steel for increased corrosion resistance.

STAINLESS STEEL FLUID PATH: This options uses the same swivel as described in the stainless steel captive bearing swivel upgrade and couples it to an upgraded 304 stainless steel plumbing axle to improve the corrosion resistance of the entire fluid path.



ADD PINLOCK TO MOTORIZED MODELS

The spring-loaded lock pin assembly is designed to lock & secure the reel, even in mobile conditions over rough terrain.



1185 SERIES

LARGE CAPACITY/VOLUME HOSE REELS



1185 In-Line Swivel Series

1185 90° Swivel Series

COXREELS® 1185 Series hand crank and motor driven hose reels are designed to handle long lengths of large diameter hose for increased volume delivery. Coxreels' exclusive low profile outlet riser and open drum design provide a noncrimping, flat smooth hose wrap. The sturdy all welded "A" frame provides exceptional strength to handle the extra weight without sacrificing performance, even in demanding mobile applications.

1185 SERIES - ALL REELS SUPPLIED LESS HOSE

MODEL	STANDARD CAP			OPTIONAL CAP. Reducer required			INLET SWIVEL & OUTLET RISER	PSI	APRX. LBS.	SIZE INDEX
	I.D.	O.D.	FT.	I.D.	O.D.	FT.				
1185 SERIES - IN-LINE SWIVEL										
1185-1124	1 1/2"	2 1/16"	50	1 1/4"	1 13/16"	75	1 1/2" F NPT	1,500	76	1
1185-1524	1 1/2"	2 1/16"	75	1 1/4"	1 13/16"	100	1 1/2" F NPT	1,500	81	2
1185-2024	1 1/2"	2 1/16"	100	1 1/4"	1 13/16"	125	1 1/2" F NPT	1,500	94	3
1185-2528	1 1/2"	2 1/16"	150	1 1/4"	1 13/16"	220	1 1/2" F NPT	1,500	122	4
1185 SERIES - 90° SWIVEL										
1185-1124-BUXX	1 1/2"	2 1/16"	50	1 1/4"	1 13/16"	75	1 1/2" F NPT	3,000	76	1
1185-1524-BUXX	1 1/2"	2 1/16"	75	1 1/4"	1 13/16"	100	1 1/2" F NPT	3,000	81	2
1185-2024-BUXX	1 1/2"	2 1/16"	100	1 1/4"	1 13/16"	125	1 1/2" F NPT	3,000	94	3
1185-2528-BUXX	1 1/2"	2 1/16"	150	1 1/4"	1 13/16"	220	1 1/2" F NPT	3,000	122	4

1185 SERIES :: REEL SPECIFICATIONS

SWIVEL

- In-line electroless nickel plated steel full-flow NPT swivel inlet
- Swivel Seals: NITRILE
- **(On high pressure models with suffix -BUXX)** External fluid path with electroless nickel plated steel 90° full-flow NPT swivel inlet
- **(On high pressure models with suffix -BUXX)** Swivel Seals: AFLAS
- Available with stainless steel fluid path

DESIGN & STRUCTURE

- All welded steel "A" frame construction for superior reel structure
- Exclusive low profile outlet riser & open drum slot design for flat smooth hose wrap
- Robust lubricated horizontal surface mount bearings for easy rotation
- **(On hand crank models)** Long-handled locking pin to secure reel from rotation during transport or storage
- Solid steel direct hand crank with smooth round handle
- Reliable chain & sprocket drive on motor driven models

! WARNING: Cancer and reproductive Harm -
For more information - www.P65Warning.ca.gov

REEL DIMENSIONS

Technical Data Sheets Available On Website

SIZE INDEX	W				H	L	X	Y	Ø	Dw
	CRANK	ELEC.	AIR / HYD.	-BUXX EQUIPPED						
1	25"	26 1/8"	23 3/8"	26 7/8"	26"	24"	17"	22 1/4"	10 1/2"	11 1/2"
2	29"	30 1/8"	27 3/8"	30 7/8"	26"	24"	21"	22 1/4"	10 1/2"	15 1/2"
3	33 1/2"	34 5/8"	31 7/8"	35 3/8"	26"	24"	25 1/2"	22 1/4"	10 1/2"	20"
4	38 1/2"	39 5/8"	36 7/8"	40 3/8"	30"	28"	30 1/2"	24 1/2"	10 1/2"	25"

Overall Dimensions Base Drum



MOTORIZED THE REWIND OF YOUR REEL

Featuring a lubricated chain and a zinc plated steel sprocket, the 1185 Series drive system provides a smooth, continuous rewind on motorized reels. Choose from several motor options shown in the table below.

SUFFIX	TYPE	DESCRIPTION	ADD ON LBS
A	AIR - 4 VANE	ALUMINUM BODY AIR MOTOR	8
AB	AIR - 6 VANE	CAST IRON AIR MOTOR	8
C	FRONT HAND CRANK	BEVEL GEARED CRANK	3
E	12 V DC, 1/3 HP	REVERSIBLE	13
ED	12 V DC, 1/2 HP EXP.	EXPLOSION PROOF, REVERSIBLE	26
EF	24 V DC, 1/3 HP	REVERSIBLE	13
EB	24 V DC, 1/2 HP EXP.	EXPLOSION PROOF, REVERSIBLE	26
EA	115 V AC, 1/2 HP EXP.	EXPLOSION PROOF REVERSIBLE AC RECTIFIED	26
EJ	230 V AC, 1/2 HP EXP.	EXPLOSION PROOF REVERSIBLE AC RECTIFIED	26
H	HYDRAULIC	END PORTED 9/16-18 UNF	6

TOP REQUESTED UPGRADES & ACCESSORIES

SEE PAGE 21 FOR ADDITIONAL ACCESSORIES



ADD 4-WAY ROLLERS

4-way enclosed pinch-proof stainless steel rollers are 1 in diameter supported by powder coated steel brackets. Weight: Add 10 lbs. to reel weight.



ADD 3-WAY ROLLERS

3-way open spool roller assembly with 1.5 chrome-plated machined steel spools & 1.5 stainless steel tubing bottom roller & powder coated steel brackets. Weight: Add 14 lbs. to reel weight.



UPGRADE TO STAINLESS STEEL

STAINLESS STEEL CAPTIVE BEARING SWIVEL / STAINLESS STEEL IN-LINE SWIVEL: the stainless steel swivel is machined from solid 304 stainless steel for increased corrosion resistance.

STAINLESS STEEL FLUID PATH: This options uses the same swivel as described in the stainless steel swivel upgrade options and couples it to an upgraded 304 stainless steel plumbing axle to improve the corrosion resistance of the entire fluid path.



ADD PINLOCK TO MOTORIZED MODELS

The spring-loaded lock pin assembly is designed to lock & secure the reel, even in mobile conditions over rough terrain.

COXREELS® 1195 Series motor driven hose reels are designed to handle long lengths of large diameter hose for increased volume delivery. Coxreels' exclusive low profile outlet riser and open drum design provide a noncrimping, flat smooth hose wrap. The sturdy all welded "A" frame base provides exceptional strength to handle the extra weight without sacrificing performance, even in demanding mobile applications.

1195 SERIES - ALL REELS SUPPLIED LESS HOSE

MODEL	LESS HOSE						INLET SWIVEL ASSEMBLY	OUTLET RISER	PSI	APRX. LBS.	SIZE INDEX
	STANDARD CAP			OPTIONAL CAP. Reducer required							
	I.D.	O.D.	FT.	I.D.	O.D.	FT.					
STANDARD 1195 SERIES WITH IN-LINE SWIVEL											
1195-932-X	2"	29 1/16"	50	1 1/2"	2 1/16"	60	2" F NPT	2" F NPT	1,000	128	1
1195-1332-X	2"	29 1/16"	75	1 1/2"	2 1/16"	100	2" F NPT	2" F NPT	1,000	148	2
1195-2032-X	2"	29 1/16"	115	1 1/2"	2 1/16"	150	2" F NPT	2" F NPT	1,000	186	3
1195 SERIES WITH 90° SWIVEL											
1195-932-X-BUXX	2"	29 1/16"	50	1 1/2"	2 1/16"	60	2" F NPT	2" F NPT	1,500	128	1
1195-1332-X-BUXX	2"	29 1/16"	75	1 1/2"	2 1/16"	100	2" F NPT	2" F NPT	1,500	148	2
1195-2032-X-BUXX	2"	29 1/16"	115	1 1/2"	2 1/16"	150	2" F NPT	2" F NPT	1,500	186	3



1195 SERIES :: REEL SPECIFICATIONS

REEL DIMENSIONS

Technical Data Sheets Available On Website

SIZE INDEX	W				H	L	X	Y	Ø	Dw
	CRANK	ELEC.	AIR / HYD.	-BUXX EQUIPPED						
1	17 7/8"	22 1/8"	19 3/8"	23"	33 1/4"	32"	15"	25 5/8"	15 1/2"	9 1/2"
2	21 7/8"	26 1/8"	23 3/8"	27"	33 1/4"	32"	19"	25 5/8"	15 1/2"	13 1/2"
3	28 3/8"	32 5/8"	29 7/8"	33 1/2"	33 1/4"	32"	25 1/2"	25 5/8"	15 1/2"	20"

Overall Dimensions Base Drum



SUFFIX OPTIONS FOR YOUR REEL

These models are not available in direct crank models. Featuring a lubricated chain and a zinc plated steel sprocket, the 1195 Series drive system provides a smooth, continuous rewind on motorized reels. Select from the options below to substitute the "X" with.

SUFFIX	TYPE	DESCRIPTION	ADD ON APRX. LBS
AB	AIR - 6 VANE	CAST IRON AIR MOTOR	8
C	FRONT HAND CRANK	BEVEL GEARED CRANK	3
EDV3	12 V DC, 1/2 HP EXP. 1:3	EXPLOSION PROOF, REVERSIBLE, IDLER	26
EBV3	24 V DC, 1/2 HP EXP. 1:3	EXPLOSION PROOF, REVERSIBLE, IDLER	26
EAV3	115 V AC, 1/2 HP EXP. 1:3	EXPLOSION PROOF REVERSIBLE AC RECTIFIED, IDLER	26
EJV3	230 V AC, 1/2 HP EXP. 1:3	EXPLOSION PROOF REVERSIBLE AC RECTIFIED, IDLER	26
H	HYDRAULIC	END PORTED 9/16-18 UNF	6

*Electric Rewind models are available without idler gears for use with electronic speed reducers, contact factory

SWIVEL

- In-line electroless nickel plated steel full-flow NPT swivel
- Swivel Seals: NITRILE
- (On high pressure models with suffix -BUXX) External fluid path with electroless nickel plated steel 90° full-flow NPT swivel
- (On high pressure models with suffix -BUXX) Swivel Seals: AFLAS
- Available with stainless steel fluid path

DESIGN & STRUCTURE

- All welded steel "A" frame construction for superior reel structure
- Exclusive low profile outlet riser & open drum slot design for flat smooth hose wrap
- Robust lubricated horizontal surface mount bearings for easy rotation
- Adaptor for Victaulic connections available, consult factory
- Reliable chain & sprocket drive on motor driven models
- Idler Gears on electric rewind models to reduce drum speed and increase torque. Default ratio: 1:3. Available in three sizes, consult factory.
- (On models with suffix -C) Bevel geared crank rewind See Motor Options Chart

WARNING: Cancer and reproductive Harm – For more information – www.P65Warning.ca.gov

TOP REQUESTED UPGRADES & ACCESSORIES

SEE PAGE 21 FOR ADDITIONAL ACCESSORIES



ADD 4-WAY ROLLERS

4-way enclosed pinch-proof stainless steel rollers are 1 in diameter supported by powder coated steel brackets. Weight: Add 10 lbs. to reel weight.



IDLER GEARS AVAILABLE

Reduce drum speed & increase torque. Available in three sizes : 1:2 ratio, 1:3 ratio (default), and 1:4 ratio, they are factory installed on the motor kits.



UPGRADE TO STAINLESS STEEL

STAINLESS STEEL CAPTIVE BEARING SWIVEL / STAINLESS STEEL IN-LINE SWIVEL: the stainless steel swivel is machined from solid 304 stainless steel for increased corrosion resistance.

STAINLESS STEEL FLUID PATH: This options uses the same swivel as described in the stainless steel swivel upgrade options and couples it to a upgraded 304 stainless steel plumbing axle to improve the corrosion resistance of the entire fluid path.



ADD PINLOCK TO MOTORIZED MODELS

The spring-loaded lock pin assembly is designed to lock & secure the reel, even in mobile conditions over rough terrain.



1 1/2" I.D.

V SERIES

VACUUM HOSE REELS

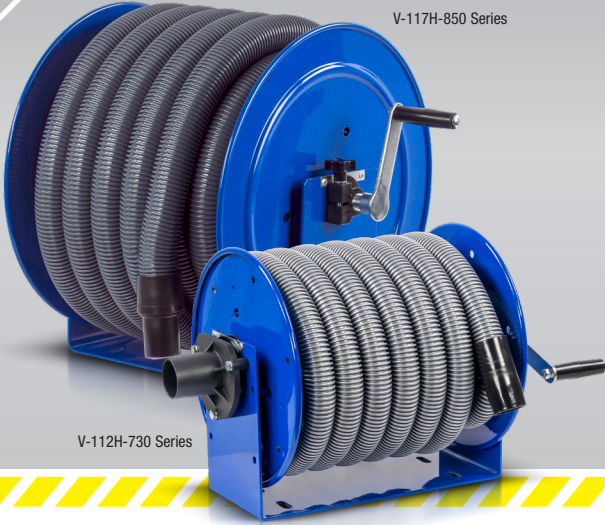

COXREELS® V Series spring driven and hand crank vacuum hose reels are available in both vacuum only and vacuum/pneumatic combinations. Both are designed to extract unwanted fumes, particles and by-products from your work area. The vacuum/pneumatic models have dual plumbing for vacuum extraction while simultaneously powering pneumatic tools such as grinders and sanders in an enclosed efficient system.

V SERIES

MODEL	DESCRIPTION	HOSE			APPR. LBS.	LESS HOSE		SIZE INDEX
		INLET	VACUUM CAP.	VAC. HP		MODEL	APPR. LBS.	
V100 SERIES								
V-112H-730	Vacuum Only, Direct Crank	1 1/2" - 2" Cuff	30' of 1 1/4" Vac hose	Less than 5HP	24	V-112-730	19	1
V-117H-835	Vacuum Only, Direct Crank	1 1/2" - 2" Cuff	35' of 1 1/2" Vac hose	Less than 5HP	35	-	-	2
V-117H-850	Vacuum Only, Direct Crank	1 1/2" - 2" Cuff	50' of 1 1/2" Vac hose	5HP or more	38	V-117-850	30	2

V-100 SERIES :: REEL SPECIFICATIONS

DESIGN & STRUCTURE

- Solid one piece, heavy gauge steel "U" shaped frame design
- Lightweight & compact design makes this reel the ideal solution for commercial vacuum systems
- Direct connect port for vacuum hose with bullet cuffs
- Adjustable tension brake to prevent "free-wheeling" during operation, transport or storage
- Swivel allows for the connection of 1 1/2" and 2" hose on the inlet.
- Open drum design for no hassle hose wrap.
- Direct hand crank rewind.

REEL DIMENSIONS

Technical Data Sheets Available On Website

SIZE INDEX	W	H	L	X	Y	Ø	Dw
1	23 1/8"	13"	12"	14 1/8"	6"	5 1/2"	12 1/2"
2	23 5/8"	18"	17"	15"	6"	6 3/4"	13 1/2"
	Overall Dimensions			Base		Drum	

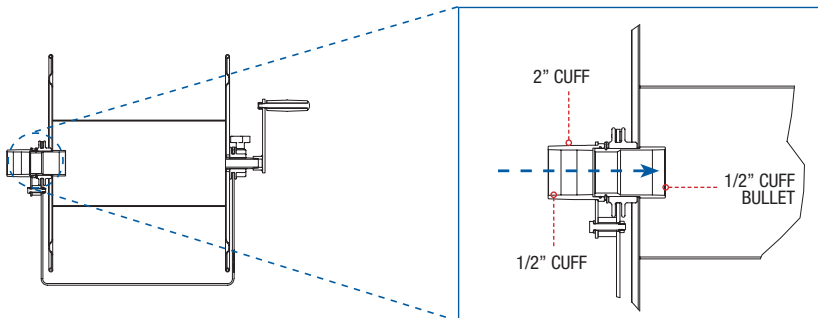
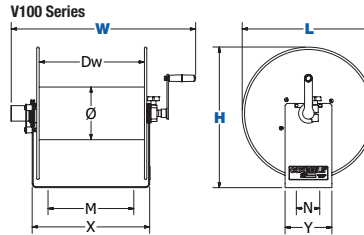

SWIVEL

The upgraded swivel allows for the connection of 2" hose on the inlet in addition to the 1.5" hose.

TOP REQUESTED UPGRADES & ACCESSORIES

SEE PAGE 21 FOR ADDITIONAL ACCESSORIES



ADD PINLOCK

The spring-loaded lock pin assembly is designed to lock & secure the reel, even in mobile conditions over rough terrain.

HAND CRANK



ACCESSORIES

SWIVELS & O-RING COMPATIBILITY CHART

	Brass	Zinc Plated Steel	Electroless Nickel Plated Steel	Stainless Steel	Aluminum	Melonized Steel
Available Swivel I.D. Female NPT fittings (*BSPT fittings available)	1/4"	•	•			•
	3/8"	•	•			
	1/2"	•	•			
	3/4"	•	•			
	1"			•		
	1 1/2"			•		
	2"			•		
Available Swivel Seals (Refer to O-Ring Compatibility Chart for desired application)	Buna	•	•	•	•	
	EPDM	•	•	•	•	
	Viton®	•	•	•	•	•
	AFLAS			•	•	

O-RING COMPATIBILITY CHART

Intended as a general guideline only. Users must test under their own operating guidelines to determine suitability. Please consult factory if your application is not listed.
1 = Recommended | **2** = Fair | **3** = Poor | **4** = Unsatisfactory

	ACETYLENE AIR (-30°F TO +25°F)	AIR (+25°F TO 200°F)	AIR (200°F TO 300°F)	AIR (300°F TO 400°F)	ANTIFREEZE	FUEL OIL / KEROSENE	GREASE (PETROLEUM BASED)	HYDROCHLORIC ACID	MOTOR OIL (PETROLEUM BASED)	NATURAL GAS	NITROGEN	OXYGEN (200°F TO 300°F)	OXYGEN (COLD)	PESTICIDES	STEAM (BELOW 300°F)	STEAM (300°F TO 400°F)	SEAWATER	WATER (UP TO 200°F)	
→	1	1	1	3	4	2	1	1	3	1	1	4	2	2	4	4	1	1	1
→	1	1	1	2	4	1	4	4	2	4	4	1	4	2	4	1	2	1	1
→	1	2	1	1	1	2	1	1	1	1	1	2	1	1	2	3	2	2	
→	1	3	1	1	1	1	2	2	1	2	1	4	2	1	2	3	1	1	



Brass Swivels

CNC machined from solid brass swivels are built for general multi-purpose applications. Configured in a 90 degree fluid path with full flow designed. Working pressure up to 3000 PSI & -40°F to 400°F*.



Zinc Plated Steel Swivels

Machined from strong low carbon steel and configured in a 90 degree fluid path with full flow designed. Zinc plated steel swivels are recommended for non-corrosive applications. Working pressure up to 5000 PSI & -40°F to 400°F*.



Electroless Nickel Plated Steel Swivels

Machined from strong low carbon steel and configured in a 90 degree fluid path with full flow designed. Nickel plated steel swivels are recommended for mildly corrosive applications. Working pressure up to 4000 PSI & -40°F to 400°F*.



Stainless Steel Swivels

Machined from high quality, pure 316 stainless steel and configured in a 90 degree fluid path with full flow design. Stainless steel swivels offer superior corrosion protection. Working pressure up to 5000 PSI & -40°F to 400°F*.



Aluminum Swivels

Machined from lightweight aluminum and configured in an in-line fluid path with full flow design. Working pressure up to 600 PSI & -40°F to 400°F*.





Melonized Steel Swivels

Configured in a 90 degree fluid path with 1/4" ports, melonized steel swivels are used for hydraulic applications. Working pressure up to 10,000 psi & -5°F to 400°F*.

*Temperature rating depends on the seal type selected

MOUNTING & ROLLER BRACKETS

	PART NO.	REEL SERIES					
		P	SH, MP & HP	T	PC	P-W & SHW	P-WC
 <p>Swing Bracket For vertical surface mounting, allows reel to swing 180°. Powder coated crinkle black 1/4" steel. Weight: 5 lbs.</p>	15720	•	•		•	•	•
	15725			•			
 <p>Swivel Bracket For horizontal surface mounting, ball bearing rotation, allows reel to swivel 345°. Powder coated crinkle black heavy gauge steel. Weight: 6 lbs. NOT FOR USE IN CEILING APPLICATIONS.</p>	15721	•	•	•	•	•	•
 <p>EZ-Up Bracket Reel easily slides in & out for easy overhead mounting. Use as an alternative to the #MR-1. Must be ordered with #15724 for "I" or "H" beam installations. Weight: 6.5 lbs.</p>	15723	•	•	•	•	•	•
 <p>EZ-Up "I" or "H" Beam Adapter Must be ordered with #15723. Powder coated crinkle black, all steel construction. Weight: 5 lbs.</p>	15724	•	•	•	•	•	•
 <p>Mounting Bracket For overhead mounting, fits 3" to 8 1/2" flange on "I" or "H" beam. Powder coated crinkle black 3/16" bent steel. Weight: 13 lbs.</p>	MR-1	•	•		•	•	•
	MRT-1			•			
 <p>4-Way Roller Bracket Heavy gauge steel, powder coated Coxreels blue (4RB) Available in stainless steel (4RB-SS). Weight: 1 lbs.</p>	4RB 1/4"-3/4"	•	•	•	•	•	•
	4RB-SS 1/4"-3/4"	•	•	•	•	•	•
 <p>4-Way Roller Bracket Heavy gauge steel, powder coated Coxreels blue with stainless steel rollers (4SRB) Available in stainless steel (4SRB-SS). Weight: 1 lbs.</p>	4SRB-4 1/2"	•	•	•	•	•	•
	4SRB-5 3/4"	•	•				
	4SRB-6 1"			•			

HOSE STOPS & GUARDS



HOSE STOPS PART NO.	HOSE GUARD PART NO.	HOSE		CORD	OVERALL
		I.D.	O.D.		
131	237-1	1/4"	1/2"	12/3 SJO	2 1/2"
131-1	237-1	-	-	16/3 SJO	2 1/2"
131-3	237-1	3/8"	2 1/32"	10/3 SO	2 1/2"
131-4	398-1	1/2"	3/4"	-	2 1/2"
254	-	1/2"	3/4"	-	3 1/2"
430	398-1	3/4"	1"	-	3 1/2"
20214	-	1"	1 9/16"	-	5"

PVC INLET HOSE ASSEMBLIES



PART NO.	FITTINGS	I.D.	LENGTH	PSI
5150-1.5	1/4" Male x Female NPT	1/4"	18"	300
5153-1.5	3/8" Male x Female NPT	3/8"	18"	300
5154-1.5	1/2" Male x Female NPT	1/2"	18"	300
5155-1.5	3/4" Male x Male NPT	3/4"	18"	300
5224-1.5	3/8" Male x Male NPT	3/8"	18"	3,000
5256-1.5	1/2" Male x Male NPT	1/2"	18"	2,500
5290-1.5	3/4" Male x Male NPT	3/4"	18"	1,500
5304-1.5	1/4" Male x Male NPT	1/4"	18"	5,000
5336-1.5	3/8" Male x Male NPT	3/8"	18"	4,000

BEND RESTRICTORS







ADD SUFFIX	I.D.	DESCRIPTION	PSI
-BxB	1/4"	Black PVC Bend Restrictor	300
-BxB	3/8"	Black PVC Bend Restrictor	300
-BxB	1/2"	Black PVC Bend Restrictor	300

Designed to limit the degree of bending without compromising the integrity of the hose assembly while also preventing the hose-end from kinking, excessive wearing, & tearing.





ACCESSORIES

4-WAY ROLLER BRACKETS

	PART NO.	100	1125	1175	1185	1195
 <p>Top Rewind 4-way enclosed pinch-proof stainless steel rollers are 1" in diameter supported by powder coated steel brackets. Specify drum width. Weight: 10 lbs.</p>	9075-8 12" disc size	•				
	9075-12.5 12" disc size	•				
	9073-8 17" disc size	•				
	9073-12.5 17" disc size	•				
	9073-18 17" disc size	•				
	15353*		•			
	15357*			•		
	15368* 28" disc size					•
	15368-1* 32" disc size					•
	15369* 24" disc size				•	
15369-1* 28" disc size				•		
 <p>Top Rewind CEILING MOUNT APPLICATIONS 4-way enclosed pinch-proof stainless steel rollers are 1" in diameter supported by powder coated steel brackets. Specify ceiling mount & specify drum width. Weight: 10 lbs.</p>	15358*		•			
	15354*		•			
 <p>Bottom Rewind 4-way enclosed pinch-proof stainless steel rollers are 1" in diameter supported by powder coated steel brackets. Specify drum width. Weight: 10 lbs.</p>	15307*			•		
	15370-1*				•	
	15370*					•
 <p>Top Rewind Extension 4-way enclosed pinch-proof stainless steel rollers are 1" in diameter supported by powder coated steel brackets. Specify drum width. Weight: 10 lbs.</p>	15353-P*		•			
	CONSULT FACTORY		•	•	•	•
 <p>4-Way Roller 4-way enclosed pinch-proof stainless steel rollers are 1" in diameter.</p>	CONSULT FACTORY		•	•	•	•

*Add drum width dimension as the suffix to the part number
EXAMPLE: An 1125-4-200 reel drum width is **12"**. Order part number: **15353-12**

3-WAY ROLLER BRACKET ASSEMBLIES

	PART NO.	1125	1175	1185
 <p>Top Rewind 3-way open spool roller assembly with 1.5" chrome-plated machined steel spools & 1.5" stainless steel tubing bottom roller & powder coated steel brackets. Specify drum width. Weight: 14 lbs.</p>	15359*	•		
	15360* 24" disc size		•	•
	15361* 28" disc size			
 <p>Bottom Rewind 3-way open spool roller assembly with 1.5" chrome-plated machined steel spools & 1.5" stainless steel tubing bottom roller and powder coated steel brackets. Specify drum width. Weight: 14 lbs.</p>	15362*	•		
	15363* 24" disc size		•	•
	15364* 28" disc size			
 <p>3-Way Roller 3-way open spool roller assembly with 1.5" chrome-plated machined steel spools & 1.5" stainless steel tubing bottom roller.</p>	CONSULT FACTORY	•	•	•

*Add drum width dimension as the suffix to the part number
EXAMPLE: An 1125-4-200 reel drum width is **12"**. Order part number: **15359-12**

1125 SERIES STACKING BRACKET

	PART NO.	1125WCL
 <p>Top Rewind Stack your 1125 Series reels for double the storage in the same work area. Powder coated crinkle black, steel construction. Weight 6 lbs.</p>	7480	•



*Add drum width dimension as the suffix to the part number
EXAMPLE: An 1125-4-200 reel drum width is **12"**. Order part number: **7480-12**

MODEL UPGRADES & ADDITIONS

	PART NO.	100	1125	1175	1185	1195
 <p>Spring Loaded Lock Pin The spring-loaded lock pin assembly is designed to lock & secure the reel, even in mobile conditions over rough terrain.</p>	9077	•				
 <p>Gear Guards Guards beveled gears or chain & sprocket from dirt & foreign matter, while also protecting operator from injury.</p>	20843		•	•	•	•
	7406		•			
	7700 24" disc size			•		
	8176					•
	8176-1 24" disc size					•
 <p>Idle Gear Reduce drum speed & increase torque. Available in three sizes, they are factory installed on the motor kits.</p>	8176-2 28" disc size				•	
	17250-2 (1:2 ratio)					•
	17250-3 (1:3 ratio)					•
 <p>Brawny Reel Upgrade Available for 1125 Series for 3,000 PSI (BX) or 5,000 PSI (BH) - 10 gauge plates welded into each disc to keep them from bowing. - Prevents deformation & eventual crushing of the drum that can be caused by hose pressure. - The center drum has been thickened from 16GA to 14GA.</p>	17250-4 (1:4 ratio)					•
	Prefix model BX		•	•		
	Prefix model BH			•		
 <p>High Temperature Drag Brake For 1/2" models</p>	7429-1-4			•		
	High Temperature Drag Brake For 3/4" models	7429-1-5			•	
 <p>Heavy Duty Band Brake Steel band lined with brake friction material. Tension is adjusted with a wing nut or a knob by hand (no tools required). - Increased braking power - Increased brake life. - Easier & more precise brake adjustment (control).</p>	8340		•	•		
	8302					•
	8302-1 90° Swivel					•
 <p>Wand Holder - Lightweight aluminum construction with black CPC™ powder finish. - 24" long with a 1.6" diameter, ideal to store pressure washing guns & other spraying devices. - Left, right, front & rear sides mount configuration.</p>	15735	•				
	 <p>Hose Strain Relief Kit - Allows the hose to be secured against the drum. - The clamp provides a strain relief when the hose is fully extended from the reel. - Allow the hose to be routed between the riser connection & the hose clamp with a proper bend radius.</p>	HSRK-050 1/2" Hose		•		
HSRK-075 3/4" Hose			•	•*		
HSRK-100 1" Hose			•	•		
HSRK-100F 1" Forestry Hose			•	•		
HSRK-125 1 1/4" Hose					•*	
HSRK-150 1 1/2" Hose				•	•*	







* With reducer (optional cap)

SPEED CONTROLLERS FOR MOTORIZED MODELS







	PART NO.	MOTOR OPTIONS							
		E	EB	ED	EA	EJ	EF	A	AB
 <p>Electric Motor Speed Controller For AC motors</p>	20868					•	•		
 <p>Control Valve Control valve for No. 4 Gast Air Motor available upon request</p>	15212							•	
 <p>Control Valve Control valve for No. 6 Gast Air Motor available upon request</p>	15212-1							•	

ACCESSORIES

SPEED CONTROLLERS FOR MOTORIZED MODELS

	PART NO.	MOTOR OPTIONS					
		E	EB	ED	EA	EJ	EF
 Explosion Proof Stationary Push Button Switch For 12V D.C. applications, must be used with solenoid. Cast 3/4" N.P.T. hub inlet.	20882	•					
 Vapor Proof Junction Box Includes box cover & gasket, has three 3/4" N.P.T. hubs.	20883	•	•	•	•	•	•
 General Purpose Reversing Switch For direct starting & reversing of A.C. rewind motor.	15210				•	•	
 Sealed Push Button Switch Weather proof, dust proof momentary contact. To be used with solenoid.	20876	•	•	•	•	•	•
 Solenoid Relay 12V D.C. for activating motor.	20877	•		•			
 Circuit Breaker 50 amp automatic reset, circuit breaker. A circuit breaker is recommended for all 12V D.C. explosion proof motors.	20878	•		•			
 Switch Box (Includes #20876, #20877, & #20878 & all parts needed to assemble the entire switch box) - Casing is powder coated crinkle black.	8281	•		•			

SPEED CONTROLLERS FOR MOTORIZED MODELS

	PART NO.	MOTOR OPTIONS					
		E	EB	ED	EA	EJ	EF
 Electrical Box & Switch - Installs on any DC electric motor kit. - Push button switch mounts to frame or to 3-Way Pin Lock. - Works with all guards and accessories.	16780-12 12 VDC	•		•			
	16780-24 24 VDC		•				•
 115/230 AC/Volt Variable Speed Controller - 10-amp fuse. - On/off push button switch. - Forward/reverse feature.	20875				•	•	
 115/230 AC/Volt Variable Speed Controller - 10-amp fuse. - On/off push button switch.	20874				•	•	
 115/230 AC/Volt Variable Speed Controller 10-amp fuse.	20873				•	•	
 12 Volt DC Electric Motor Variable Speed Controller On/off push button switch. • Relay, 50-amp circuit breaker. • Forward/reverse feature.	20872	•		•			
 12 Volt DC Electric Motor Variable Speed Controller On/off push button switch. • Relay, 50-amp circuit breaker.	20871	•		•			
 12 Volt DC Electric Motor Variable Speed Controller	20870	•		•			

CUSTOMIZE YOUR REEL FROM CONCEPT TO COMPLETION







CUSTOMIZE YOUR REEL WITH COXREELS CUSTOM PRODUCTS:

Our engineering capabilities and manufacturing processes allow us to design and build top quality products for any conceivable application where reels are needed.

- Customize fluid paths/axes or create custom brackets, mounts, and accessories.
- Integrate with your specific hardware, systems, or devices.
- Modify drums, add divider disks, manipulate openings, or integrate hose handling devices.
- Combine features of various reel model lines, creating your own hybrid reel.
- Create custom retraction systems.
- Increase temperature and pressure capabilities, or multiply fluid paths.
- The possibilities are only limited by your imagination!

POWDER COAT OPTIONS*

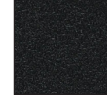
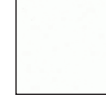
3 digit suffix for spring driven or 4 digit suffix for hand crank & motorized models.

			
-BXX or -BXXX Blue	-RXX or -RXXX Red	-GXX or -GXXX Gray	
			
-KXX or -KXXX Gloss Black	-CXX or -CXXX Crinkle Black	-WXX or -WXXX White	-NXX or -NXXX Green

*Minimum quantity & or dollar amount may apply



EZ-COIL®

SAFETY REWIND SYSTEM

EZ-Coil® is a patented controlled retraction technology offered exclusively on Coxreels' Safety Series reels. EZ-Coil® retracts up to 80% slower than conventional reels, resulting in workplace safety, protection from injury & costly property damage. **NOBODY SHOULD BE WITHOUT EZ-COIL®!**

up to **80% Slower Retraction**

	Conventional SPRING DRIVEN REELS	COXREELS EZ-COIL
SPEED	25 ft./sec.	5 ft./sec.
WHIPPING	5-15 ft.	1 ft.
IMPACT	500 ft./lbs.	0-1 ft./lbs.

Based on an independent evaluation performed by COXREELS. Depending on certain conditions, results may vary.



INDUSTRY CATALOGS



PRODUCT CATALOGS



100 years
Coxreels
 USA made since 1923

CORPORATE HEADQUARTERS:

Tempe, Arizona USA
 P: 480.820.6396 F: 480.820.5132
 Toll Free: 800.COX.REEL
www.coxreels.com info@coxreels.com

INTERNATIONAL:

EUROPE / MIDDLE EAST / AFRICA
 P: +44 (0) 1536 464 990
 F: +44 (0) 1536 464 999
www.crireels.com sales@crireels.com

