

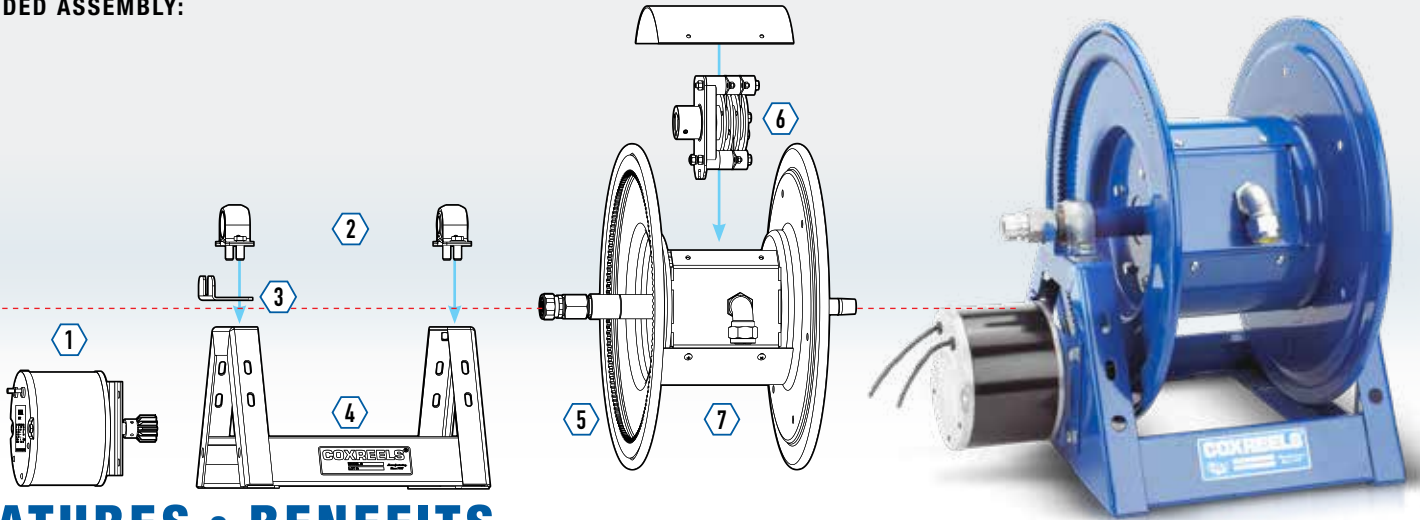

FEATURE FOCUS MOTORIZED CORD REEL

FF-MDCR-01

EXPLODED ASSEMBLY:



FEATURES & BENEFITS

STEEL CONSTRUCTION

High-Quality steel construction provides superior strength and durability for heavy-duty applications in commercial and industrial settings.



POWDER COAT

CPC™ Powder Coat. Long lasting, chip resistant and rust inhibiting CPC™ powder coat finish seals all steel components for maximum corrosion resistance.

1 CHOICE OF MOTOR

Customize reel to specific application:

Motor A	Air - 4 VANE Aluminum Body Air Motor	8 lbs
Motor AB	Air - 6 VANE Aluminum Body Air Motor	8 lbs
Motor E	Elec. - 12V DC 1/3 HP Reversible	13 lbs
Motor EF	Elec. - 24V DC 1/3 HP Reversible	13 lbs
Motor EB	24v DC 1/2 HP EXP. Explosion Proof Reversible	26 lbs
Motor ED	12v DC 1/2 HP EXP. Explosion Proof Reversible	26 lbs
Motor EA	115V AC 1/2 HP EXP. Explosion Proof Reversible, AC Rectified	26 lbs
Motor EJ	230V AC 1/2 HP EXP. Explosion Proof Reversible, AC Rectified	26 lbs
Motor H	Hydraulic End Ported 9/16-18 UNF	6 lbs



2 PILLOW BLOCK BEARINGS

Pillow Block Bearings – Sturdy permanently lubricated and self-aligning pillow block bearings for smooth rotation and trouble-free operation.

- Robust lubricated horizontal surface mount bearings on 1-1/2" and 2" hose I.D. models.



3 CABLE KEEPER

Integrated anti-rotation cable keeper prevents the 5 foot lead cable from whipping or twisting.



4 "A" FRAME

Sturdy one piece, all CNC robotically welded 1/4" steel "A" frame base, not bolted, for superior reel structure and narrow width for convenient installation in restricted spaces

Mounting Pattern – Mounting pattern located in the steel base for easy reel installation and detachment.



5 DIRECT DRIVE MOTOR

A solid steel halo is welded to the disc for a safe and reliable direct gear drive retraction on 1125 and 1275 Series.

- Lubricated chain and zinc plated steel sprocket on larger motorized 1175, 1185 and 1195 Series.



6 SLIP RING ASSEMBLY

Drum-located slip ring assembly with easy to access removable panel for simple routine maintenance.

- Available with 30AMP or 45AMP, 600V rated slip ring assembly.



7 CNC SPUN DISCS

Heavy duty CNC robotically spun and ribbed discs with rolled edges for greater strength, durability, cord protection and operator safety.



ACCESSORIES & UPGRADES



WWW.COXREELS.COM
INFO@COXREELS.COM

5865 S. ASH AVE
TEMPE, AZ 85283

800.COX.REEL
480.820.6396

#COXREELS

