

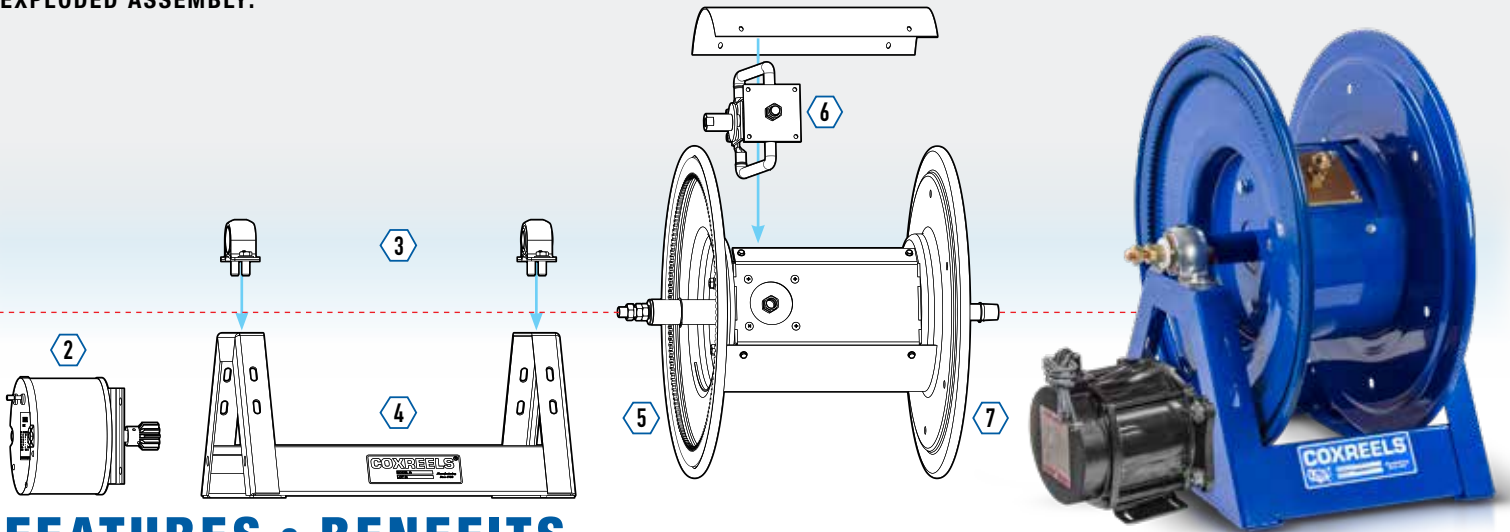

# FEATURE FOCUS MOTORIZED WELDING REEL

FF-MDWR-01

EXPLODED ASSEMBLY:



## FEATURES & BENEFITS

### STEEL CONSTRUCTION

High-Quality steel construction provides superior strength and durability for heavy-duty applications in commercial and industrial settings.



### POWDER COAT

CPC™ Powder Coat. Long lasting, chip resistant and rust inhibiting CPC™ powder coat finish seals all steel components for maximum corrosion resistance.

### 1 WELDING GAS SWIVEL



Designed for Oxy-Acetylene and T Grade twin line welding hose. Dual machined from solid brass 90° full-flow 3/8" NPT swivels (1 on each side of the reel) for simple VITON® seal maintenance and fast and easy hose installation. No need to remove the reel from its mount. - On Motorized Welding Hose Reel models only.

### 2 CHOICE OF MOTOR



Customize reel to specific application:

<b>Motor A</b>	Air - 4 VANE Aluminum Body Air Motor	8 lbs
<b>Motor EB</b>	Elec. - 24v DC 1/2 HP EXP. Explosion Proof Reversible	26 lbs
<b>Motor ED</b>	Elec. - 12v DC 1/2 HP EXP. Explosion Proof Reversible	26 lbs
<b>Motor EA</b>	Elec. - 115V AC 1/2 HP EXP. Explosion Proof Reversible, AC Rectified	26 lbs
<b>Motor H</b>	Hydraulic End Ported 9/16-18 UNF	6 lbs

### 3 PILLOW BLOCK BEARINGS



Pillow Block Bearings – Sturdy permanently lubricated and self-aligning pillow block bearings for smooth rotation and trouble-free operation.

### 4 "A" FRAME



Sturdy one piece, all CNC robotically welded 1/4" steel "A" frame base, not bolted, for superior reel structure.

Mounting Pattern – Mounting pattern located in the steel base for easy reel installation and detachment.

### 5 DIRECT DRIVE MOTOR



A solid steel halo is welded to the disc for a safe and reliable direct gear drive retraction on 1125 and 1275 Series.

- Lubricated chain and zinc plated steel sprocket on larger motorized 1175, 1185 and 1195 Series.

### 6 SLIP RING ASSEMBLY



Drum-located slip ring assembly with easy to access removable panel for simple routine maintenance.

- On Motorized Welding Cable Reel models only.

- Electrical current runs through a heavy-duty 450 AMP rated slip ring.

### 7 CNC SPUN DISCS



Heavy duty CNC robotically spun and ribbed discs with rolled edges for greater strength, durability, hose protection and operator safety.

## ACCESSORIES & UPGRADES



ROLLER BRACKETS



SPEED CONTROLLER



GEAR GUARDS



STACKING BRACKET



WWW.COXREELS.COM  
INFO@COXREELS.COM

5865 S. ASH AVE  
TEMPE, AZ 85283

800.COX.REEL  
480.820.6396

#COXREELS

